



CERTIFICATE OF PLAGIARISM CHECK

To Whom It May Concern:

This is to certify that the following document has been checked by our premium plagiarism checker software. The result detail is as follows:

MANUSCRIPT TITLE	CHANGES OF AMINO ACID CONTENT IN MANGGABAI FISH OF FERMENTATION RESULTS
Author(s)	Faiza A. Dali Rita Marsuci Harmain
Document's Plagiarism percentage	1%
Minimum percentage	20%
Remark(s)	-

Gorontalo, 09 April 2018

Novriyanto Napu, PhD
Director



TRANSBAHASA

SK Menteri Hukum dan HAM RI Nomor. AHU-0009641.AH.01.07.2017

JL. Ir.H. Joesoef Dalie No. 78 Kota Gorontalo

Email. transbahasa.go@gmail.com / Phone. +62 853 9862 5876

www.transbahasa.co.id



PROCEEDINGS



“EDUCATIONAL CHALLENGES AND STRATEGIES OF HIGHER EDUCATION IN HEALTH/ACHIEVEMENT OF SDGS 2030”

Hotel Damhil UNG, Gorontalo City, Sept 27th 2017

BOOK 3

SUSTAINABLE
DEVELOPMENT
GOALS



**PUBLIC HEALTH DEPARTMENT
SPORT AND HEALTH FACULTY
GORONTALO STATE UNIVERSITY**



THIRD INTERNATIONAL SEMINAR ON PUBLIC HEALTH AND EDUCATION (ISPHE) PROCEEDINGS

Public Health Department, Sport and Health Faculty, Gorontalo State University

Published by

Public Health Department Sport and Health Faculty Gorontalo State University
Gorontalo City, Gorontalo Province, 96128 Email: Kesmasung2017@gmail.com
Telp. – Fax. +628435821698

This publication is in copyright. Subject to statutory exception and to the provisions of relevant collective licensing agreements, no reproduction of any part may take place without the written permission of the Public Health Department, Sport and Health Faculty, Gorontalo State University.

First published in September 2017

Editor : Sri Manovita Pateda, Rani Hiola, Oktia
Woro K.H., Kukiati Tudpor, Febi Dwirahmadi, Kraicat
Manuscript Team : Lilyandra Pobela, Dessy Nur Anggriani Deu, Rahayu
Putri Veybe M. Yantu, Selvi Ahmad, Christian J. Ottay,
Novalin Bau, Mei Bobihu.
Layout : Lilyandra Pobela
Cover Design : Fery Fadly M. Umar

Library cataloguing in Publication Data:

Third International Seminar on Public Health and Education (ISPHE) Proceedings published the Public Health Department, Sport and Health Faculty, Gorontalo State University – includes bibliographical references.
Series ISBN 978-602-6204-25-7

Distributed by :

Public Health Department Sports and Health Faculty Gorontalo State University
Gorontalo City, Gorontalo Province, 96128 Email: kesmasung2017@gmail.com
Telp. – Fax.+628435821698

PREFACE

Assalamu'alaikum warrahmatullahi wabarakatuh

Firstly, may we made our highest praise and thank to Allah The Almighty, for His bless so what we are able to conduct such an precious moment; Third International Seminar on Public Health and Education 2017 in Gorontalo Indonesia, to share our knowledge and ideas with so much warm and friendship from worldwide public health and education community.

International Seminar on Public Health and Education 2017 is aimed to gather all of experts, researchers, academicians and practitioners in health education field in general as well as national and international level in one prestigious academic forum which to discuss all health-education-related issues, ranging from human resources, curriculum, institutionalization ect. The seminar also proposed to contribute to the focus of health development direction; by considering also situation and the status of local health condition from each region, both national and regional levels as well as its relation to global health trends.

I would like to deliver our highest respect and appreciation to our honorable speakers, Dr. Jihane Tawilah (WHO Indonesia Representative), Prof. Dr. dr. Oktia Woro K.H., M.Kes (Keynote Speaker from Semarang State University), Febi Dwirahmadi, SKM, MSc.PH, PhD (Centre of Environment and Population Health School of Medicine, Griffith University, Australia), Prof. Kraichat Tantrakarnapa (Mahidol University), and Dr. Kukiattudpor, PhD (Mahasarakham University). I really expect that this seminar will be beneficial for all of us and to the development of the Public Health and Education field.

Allow me to express my gratitude to the participants and audiences from Indonesia and other foreign countries who are enthusiastic in attending this seminar. I do hope that all audiences will gain important values and collaborate it into our fields and make significant changes in the future. Besides that, I also

convey my appreciation to all of organizing committee who has given their outstanding commitment for presenting this occasion.

Wassalamu'alaikum warrahmatullahi wabarakatuh

Content

Cover.....	i
Preface.....	iii
Content.....	v

ORAL PRESENTATIONS

- 1. Ecosocial Analysis Of Dengue Fever Incident In Sub District Of Kota Tengah, Gorontalo City**
Lintje Boekoese, Gorontalo State University. Indonesia..... 1
- 2. Relationship Between Socio-Cultural And Socio-Economic With Nutritional Status Of Children Under Five Years In Pkm Kabila, Bone Bolango Regency**
Sunarto Kadir. Gorontalo State University. Indonesia..... 2
- 3. Analysis Of Zink And Fe In Blood To Children Of Malaria Patients**
Laksmyn Kadir. Gorontalo State University. Indonesia..... 14
- 4. The Relationship Between Behavior Of Gorontalo People In Consuming Food With Coronary Heart Disease Incident In Rsud Prof.Dr.H.Aloei Saboe Gorontalo City**
Herlina Yusuf¹⁾, Siti Rahma²⁾, Edwina R. Monayo³⁾, Ismet Habb⁴⁾. Gorontalo State University. Indonesia..... 15
- 5. Lead Content In Hair And Health Problems At Workers In Spbu (Gas Station) Of Gorontalo City In 2017**
Ekawaty Prasetya¹⁾, Herlina Yusuf²⁾. Gorontalo State University. Indonesia..... 16
- 6. Supplementation Of Snakehead Fish Extract Toward Malondialdehyde(Mda)Level In Post-Stroke Patients**
Vivien Kasim¹⁾, Sri Manovita Pateda²⁾, Veni Hadju³⁾, Nurhaedar Jafar⁴⁾. Gorontalo State University. Indonesia..... 17
- 7. The Impact Of Lighting Intensity On The Issue Of Eyestrain Of Karawo Artisans In Gorontalo**
Reni Hiola¹⁾, Rama Hiola²⁾, Lanto Mohamad³⁾, Kamil Amal⁴⁾. Gorontalo State University. Indonesia..... 18

8.	The Influence Of Characteristic And Motivation Toward Performance Of Basic Immunization Workers At Puskesmas At Bone Bolango District Rama Hiola ¹⁾ , Anti Igrisa ²⁾ . Gorontalo State University. Indonesia.....	19
9.	An Analysis Of Factor Related To Malaria Incident At Elementary School Student Lia Amalia. Gorontalo State University. Indonesia	20
10.	Risk Assessment Of Heavy Metals Exposure On Oreochromis Musambicus In Limboto Lake Gorontalo Province Nurayini S. Lalu. Gorontalo State University. Indonesia	28
11.	Effects Of Self Efficacy And Collective Efficacy On Prevention Behavior Of Community With Hypertension In Gorontalo Province Irwan. Gorontalo State University. Indonesia.....	29
12.	Determinant Analysis Male Partner Involment In Prevention Of Hiv Transmission From Mother Tochild Program In Pkm Jumpandang Sabrina Nadjib M. Gorontalo State University. Indonesia.....	30
13.	Diseases Of Jembrana In Bali Cattle In Gorontalo Tri Ananda Erwin Nugroho ¹⁾ , Nibras K. Laya ²⁾ , Syam Kumaj ³⁾ i, Asmarani K. ⁴⁾ , Peny Humaida ⁵⁾ . Gorontalo State University, Gajah Mada Of University. Indonesia.....	41
14.	Protein Analysis Otilapia Fish Flour Lilik Hidayanti, SKM, MSi ¹⁾ Sri Maywati, SKM, Mkes Faculty of Health Science, University of Siliwangi, Tasikmalaya, Indonesia.....	42
15.	Identify The Number Of Medical Recorder Along With Educational Qualification At Non- Government Hospital In Gorontalo City Rahman Suleman, M.Kes, Gorontalo. Indonesia.....	47
16.	Working Station Model Based On Antropometry Mathematic Model For Employment Workers Asep Suryana, TasikMalaya. Indonesia.....	48

17.	Sexual Behavior Differences In Adolescent Risk Students Who School In Urban And Rural Schools Gorontalo	
	<i>Dewi Kartika, Gorontalo University. Indonesia.....</i>	59
18.	Analysis Of Use Of Health Care Service In Jkn Program By Participants Pbi	
	<i>Rian Arie Gustaman, Kamiel Roesman Bachtiar. Indonesia.....</i>	67
19.	The Relationship Among Knowledge Andmotivation Withsmoking Behavior Of Adolescent At Smkn 3 Gorontalo City	
	<i>Edwina R Monayo, Kevin E. Tololiu, Gorontalo. Indonesia.....</i>	68
20.	Analysis Of Neonatal Competency Risk Factorsin Gorontalo district	
	<i>Wahyuni Hafid, Novita Sari. Gorontalo. Indonesia.....</i>	81
21.	General Risk Factors Of Gravidarum Hiperemesis In Pregnant Woman In General Hospital Regions Bolaang Mongondow Selatan,	
	<i>Rahmawati¹, Rifai Alf². Bolaang Mongondow Selatan. Indonesia.....</i>	88
22.	Spatial – Temporal Analysis Incidence Of Dengue Hemorrhagic Fever (Dhf) Against Weather Variable In Limboto And Telaga Biru District, Gorontalo Regency Year 2012-2015	
	<i>Ririn Pakaya¹. Gorontalo University, Indonesia.....</i>	99
23.	Analysis The Differences Incidence Of Stunting Age 24 -59 Months In Mountains Area And Coastal Marine In Gorontalo Regency,	
	<i>Yeni Paramata, Rahmawati, Zul Adhayani Arda, Faculty of Public Health, Gorontalo University. Indonesia.....</i>	100
24.	Influence Of Leader’s Behaviour, Motivation, And Work Satisfaction Toward Organizational Citizenship Behaviour (Ocb) Of Nurses.	
	<i>Wirda Y. Dulahu¹, Dzohra Puasa². Gorontalo State University. Indonesia.....</i>	101
25.	Identification of Bacteri Racing and Nutrition Content In Pindang Tuna Fish For Sale In Traditional Market Ciawi District Tasikmalaya	

	<i>Dian Saraswati¹⁾ dan Ai Sri Kosnayani¹⁾. Siliwangi University Tasikmalaya. Indonesia.....</i>	111
26.	<i>Intestinal Parasiter - Zoonosis Disease Study Of Goat In Gorontalo District</i> <i>¹Tri Ananda Erwin Nugroho, ²Nibras K. Laya, ³Sarifudin H. Hiola, ⁴Sarwono S. Prasejo, ⁵Herman S. Wahab, Gorontalo State University, Indonesia.....</i>	112
27.	<i>Analysis Of Factors That Contribute To Targets Baby Visit In Halmahera Clinic Semarang</i> <i>Muhammad Iqbal¹⁾, Bambang Wahyono²⁾. Semarang State University. Indonesia.....</i>	113
28.	<i>Factors Associated With Disability On Leprosy Patients</i> <i>Nanang R. Paramata¹⁾, Zuhriana K. Yusuf²⁾, Wirda Y. Dulahu³⁾. Gorontalo State University. Indonesia.....</i>	114
29.	<i>Effectiveness Of Nutritional Mentoring In Implementation Of Energy Consumption And Nutrition Status On Taekwondo Athletes</i> <i>Irwan Budiono. Semarang State University. Indonesia.....</i>	115
30.	<i>Assistance Of Health Volunteers In Integrated Post Service Toward The Pattern Of Complementary Feeding Among 6-24 Months Old In Sukoharjo Regency</i> <i>Ainur Rohmah¹⁾, Mardiana²⁾, Lukman Fauzi³⁾. Semarang State University. Indonesia.....</i>	116
31.	<i>Changes Of Amino Acid Content In Manggabai Fish Of Fermentation Results</i> <i>Faiza A. Dal¹⁾, Rita Marsuci Harmain²⁾. Gorontalo State University. Indonesia.....</i>	121
32.	<i>Contribution Percentage Of Fatty Body Thickness To Physical Fitness Index Athlete Wrestling</i> <i>Rubianto Hadi¹⁾, Rivan Saghita Pratama¹⁾. Semarang State University, Indonesia</i>	127
33.	<i>The Effect Of Theobromine And Caffeine On The Level Of Muscle Fatigue After Physical Activity Maximum</i>	

	<i>Sugiarto¹, Taufiq Hidayah¹ dan Aan Wahyu Setiawan¹, Semarang State University, Indonesia.....</i>	140
34.	Case-Finding Model Of Malnourished Children (Under And Over-Nutrition) In Indonesia <i>Lukman Fauzi^{1*}, Oktia Woro Kasmini Handayani¹, Setya Rahayu². Semarang State University, Indonesia.....</i>	150
35.	The development of personal computer based accelerometer To find out the characteristics of sprint By using wireless technology <i>Andry Akhiruyanto, S.Pd, M.Pd¹. Semarang State University. Indonesia.....</i>	154



ORAL PRESENTATIONS

ECOSOCIAL ANALYSIS OF DENGUE FEVER INCIDENT IN SUB DISTRICT OF KOTA TENGAH, GORONTALO CITY

Dr. LINTJE BOEKESOE, M.KES

ABSTRACT

Gorontalo is one of the provinces Province endemic Dengue Fever. amount of dengue fever cases in province Gorontalo from year to year experience fluctuation, by because that needed handling for tackle problem The dengue disease. Sub district of kota tengah is one of the area with amount dengue fever cases tallest. research this aim for analyze ecosocial against dengue fever Center Health Society from Central City District, Gorontalo. Research this use design case control or research retrospective for knowing relationship factor risks affecting incidence of dengue fever (relationship causation). Sample group case research this is all people looking treatment in Puskesmas and they claimed that they suffering from dengue fever. While the sample group control from research this is all people looking treatment in Puskesmas and they claimed that they no suffering from dengue fever. Based on the results of risk factors incidence of dengue in sub district of kota tengah Ecological factors (environmental) associated with the incidence of dengue is the presence of stagnant water, presence of shrubs / weeds around the house, Condition of the house wall. while those not associated with the incidence of dengue is the presence of livestock (cattle sheds). The climate factors such as temperature, humidity, rainfall, duration of exposure and the speed of the wind direction is still appropriate for the breeding of dengue vectors. Social factors associated with the incidence of dengue is the knowledge of respondents, while Social factors (behavioral) associated with the incidence of dengue is a habit use netting when sleeping at night, whereas social factors (behaviors) that are not associated with the incidence of dengue fever is the habit of using a wire gauze on ventilation, habitual use of mosquito repellent, and outdoor habits at night. For social factors (attitude) either positive or negative attitude attitude no correlation with the incidence of dengue. Logistic regression results of several variables ecological factors and social factors (*ecososial*) showed that 5 (five) variables related to the incidence of dengue. The most dominant risk factors probably contribute to the incidence of dengue for the ecological factor is the presence of puddles. As for the most dominant social factors is the habit of using mosquito nets.

Word Keywords: Dengue Fever, Ecososial, Ecology, Social factor

Email : lintjeboekoesoe@gmail.com

**THE IMPACT OF SOCIO-ECONOMY AND SOCIO-CULTURAL
CONDITION ON THE CHILDREN'S NUTRITIONAL STATUS IN
KABILA COMMUNITY HEALTH CENTRE
BONE BOLANGO REGENCY**

Sunarto Kadir

ABSTRACT

Children's nutritional status refers to the condition of children's health based on the needs of their physical energy and other nutrition from foods. The physical impact regarding nutritional status is measured through anthropometry. This raises a question whether the socio-economy and socio-cultural condition affect children's nutritional status in which later acts as the aim of this study.

This observational analytic research employed the *cross-sectional study* approach. The population of this research involves all 1966 women in the working area of the Kabila community health center (*puskesmas*); the total population of the children is 300. Furthermore, the *Chi-Square* test was applied to analyze the data.

The results reveal that there is an interrelation between women's occupation and children's nutritional status, p-value 0.048; similarly, women's knowledge p-value=0.05, as well as tradition and habitual action p-value=0.036 also contributes to the nutritional status. On the contrary, personal belief's does not influence the nutritional status of the children, p-value=0.409.

In other words, the socio-economy and socio-cultural condition of women plays a major role in shaping children's nutritional status. However, this does not apply to the indicator of personal beliefs. It is expected that the nutrition officers to conduct workshops or seminars to raise the awareness and the contribution of the community towards the nutritional issue.

Keywords: Children's Nutritional Status, Socio-Economy, Socio-cultural

1. INTRODUCTION

A toddler is a child 12 to 36 months old (under five years of age). Within the period, children require a special treatment from their parents. This is because of the parents, particularly mother, play a significant role in shaping the children's development. Also, the mother must consider the foods as it is the resource of children's nutrition. These are to maximise children's growth and development since during such a period; they are prone to nutritional problems.

The economic factor is among contributing factors to the children's nutritional status. A high economic status of a family is able to ensure that the needs of each family member, including the children's nutrition, are met. Such a high status is based on a number of aspects, such as occupation, family's income, wealth, expenditures, and expenses on foods (Supariasa, 2012). A low economic status is in the first rank among contributing factors of the issue of malnutrition.

The nutritional problem remains a serious problem despite the decline in the percentage of the total population of poor people, 16.6 percent - 12.5 percent, in Indonesia, in 2007 to 2011 (UNICEF, 2012). In other words, the economic condition is among the aspects measured to examine the success of a nation. In 2006, the data by National Statistics Board (*Badan Pusat Statistik* or *BPS*) reported that there had been a decrease in the economic status of Indonesia compared to the previous year. The percentage of the economic growth was 5.7 percent back in 2005, and it was decreased to 5.5 percent in 2006. However, one year later, in 2007, there was a significant increase in the percentage of the nation's economic growth to 6.3 percent. This trend had remained the same in the following year, 2008; even it was slightly higher with 6.1 percent which outnumbers the one in 2007. The percentage continued to increase in 2009 4.5 percent, and in 2010 6.1 percent (Depkes RI, 2010). The economy factor significantly influences the issue of children's nutrition, especially in providing the children with nutritious foods.

According to the Report on Monitoring of Nutritional Status (*Laporan Pemantauan Status Gizi* or *PSG*) and the Nutrition level (*Kadarzi*) within Bone Bolango regency, in 2015, the distributions of children's prevalence rate, based on the indicator of weight/age, are 2.86 percent identified as malnutrition, 11.88 percent identified as undernutrition, 84.65 percent classified as adequate nutrition, while 0.65 percent classified as excessive nutrition (Dinkes, Kab.Bone Bolango, 2015). The data by the Health Service of Bone Bolango regency indicates that the issue of nutrition is present almost every year in Kabila community health center. It blames the disproportion of nutrients from the foods consumed in which leads to

more serious issues regarding the children’s nutrition; for instance, a child whose diet is lack of nutrition will worsen his or her nutritional status.

By that, examining the relationship between the socio-economic and socio-cultural condition with the children’s nutritional status in the work area of Kabila community health center, Bone Bolango regency, is necessary.

2. RESEARCH METHODOLOGY

2.1 Site and Time of Research

This study was conducted on 7th of June to 7th of July, 2016. Furthermore, the site object was the work area of Kabila community health center (*Puskesmas*), Bone Bolango regency.

2.2 Design of research

This observational-analytic research employed *cross-sectional study* approach in gathering the data regarding the variable of occupation, the condition of socio-economic, as well as the children’s nutritional status. Furthermore, these steps were conducted at the time.

2.3 Population of sample

The population of this study involved women within the site object who have children; with the total of 1966 women.

Further, the random sampling method was used to select the sample among the population. Therefore, the total respondents of this research was 333 women with toddlers. The sample was selected based on particular criteria set for this study. The criteria involved inclusion which refers to the total 300 women as the sample, and exclusion which specifies the other 33 women.

2.4 Data Analysis

This study used a number of statistic tests, e.g., univariate and bivariate analysis; in the bivariate analysis, two tests, namely *chi-square* and *exact fisher*, were also involved.

3. RESULTS AND DISCUSSION

3.1 Research results

Table 3.1 Distribution of the Total of Population within the Work Area of Kabila Community Health Centre, Bone Bolango Regency, 2016, Based on the Gender

Gender	Frequency	Percentage
--------	-----------	------------

Male	146	48.7
Female	154	51.3
Total	300	100

From: Primary data, 2016

The above table indicates that women dominate the total population of the society in the site object, with 154 women (51.3 percent), while the total population of men is 146 (48.7 percent).

Table 3.2 The Interrelation of Women’s Occupation and the Children’s Nutritional Status in the Target Area of Kabila Community Health Centre, 2016

Occupation of Women	Nutritional status Weight/Age						X ²	p-value
	Poor Nutritional Status		Good Nutritional Status		Total			
	n	%	n	%	n	%		
Temporary work	80	76.8	127	65.1	207	69	3.905 ^a	0.048
Permanent employment	25	23.2	68	34.9	93	31		
Total	105	100	195	100	300	100		

From: Primary data, 2016

Table 3.2 shows that 207 among 300 respondents within the site object are temporary employees. In regards to the nutritional status, 127 of the children, 65.1 percent, are in the good category and the other 80, 76.8 percent, are in the poor category. In terms of the nutritional status of children of the women who are permanent employees, 68 of the children, 34.9 percent, are in the good category and the other 25, 23.2 percent, are in the poor category.

The result of *chi-square* test shows the value of X² count 3,942^a and X² table 3.84. In other words, X² count outnumbers the X² table with the probability 0.048. Therefore, the p-value count, 0.048, is also higher than the p-value table, 0.05. It can be inferred that women’s occupation contributes to the children’s nutritional status since the null hypothesis is rejected and the alternative hypothesis is accepted.

Table 3.3 The Interrelation of Women’s Knowledge and the Children’s Nutritional Status in the Target Area of Kabila Community Health Centre, 2016

Nutritional status Weight/Age							X ²	p-value
Knowledge	Poor Nutritional Status		Good Nutritional Status		Total			
	n	%	n	%	n	%		
Low	5	4.9	0	0	5	1.7	9,443 ^a	0.005
Good	100	95.1	195	100	295	98.3		
Total	105	100	195	100	300	100		

From: Primary data, 2016

Table 3.3 shows that five among 300 respondents within the site object is categorized low in terms of the knowledge which all of them are in the good nutrition category, 4.9 percent. In regards to the nutritional status in the 295 children, 195 of them, 100 percent, are in a good category and the other 103, 95.1 percent, are in the poor category. The *exact fisher* test indicates that there are two *cells* which are under 5.

The result of *chi-square* test shows the value of X² count 9.443^a and X² table 3.84. In other words, X² count outnumbers the X² table with the probability 0.005. Therefore, the p-value count, 0.005, is also higher than the p-value table, 0.05. It can be inferred that women's knowledge influences the children's nutritional status.

Table 3.4 The Interrelation of Tradition and Customs and the Children's Nutritional Status in the Target Area of Kabila Community Health Centre, 2016

Nutritional status Weight/Age							X ²	p-value
Habit	Poor Nutritional Status		Good Nutritional Status		Total			
	n	%	n	%	n	%		
Bad	72	68.3	155	79.8	227	75.7	4.417 ^a	0.036
Good	33	31.7	40	20.2	73	24.3		
Total	105	100	195	100	300	100		

From: Primary data, 2016

Table 3.4 shows that 73 out of 300 respondents in the site object are in the good category regarding the frequency of the foods consumption. In terms of the nutritional status, 40 of the children, 20.2 percent, are in a good category and the other 33, 31.7 percent, are in the poor category. The total 227 respondents who are categorized poor in terms of foods

consumption are mostly children with the total 155, 79.8 percent of good category and the other 72, 68.3 percent, are in the poor category.

Furthermore, the result of *chi-square* test shows the value of X^2 count 4.417^a and X^2 table 3.84. In other words, X^2 count outnumbers the X^2 table with the probability 0.036. Therefore, the p-value count, 0.036, is also higher than the p-value table, 0.05. It can be inferred that the tradition and customs contribute to the children’s nutritional status due to the finding that the null hypothesis is rejected and the alternative hypothesis is accepted.

Table 3.5 The Interrelation of Personal Beliefs and the Children’s Nutritional Status in the Target Area of Kabila Community Health Centre, 2016

Nutritional status Weight/Age							X^2	p-value
Belief	Poor Nutritional Status		Good Nutritional Status		Total			
	n	%	n	%	n	%		
With dietary restrictions	79	75.1	138	70.3	217	72.3	0,681 ^a	0.409
Without dietary restrictions	26	24.9	57	29.7	83	27.7		
Total	105	100	195	100	300	100		

From: Primary data, 2016

Table 3.5 shows that 217 out of 300 respondents in the site object restrict some of dietary for their children; furthermore, within the total 138 of the children, 70.3 percent, are in a good nutrition category and the other 79, 75.1 percent, are in the poor category. The other 83 respondents do not restrict the diet for their children. In this regard, 57 of the children, 29.7 percent, are in the good nutritional category and the other 26, 24.9 percent, is the opposite.

In addition, the result of *chi-square* test reveals the value of X^2 count 0.681^a and X^2 table 3.84. In other words, X^2 count outnumbers the X^2 table with the probability 0.409. As a result, the p-value count, 0.409, is also higher than the p-value table, 0.05. It can be inferred that the aspect of personal beliefs does not play any major role on the children’s nutritional

status. This is because the null hypothesis is accepted and the alternative hypothesis is, however, rejected.

3.2 Discussion

3.2.1 The Influence of Women's Occupation on the Children's Nutritional Status

The results reveal that the null hypothesis is rejected and the alternative hypothesis; this is for the data regarding the respondents who work as temporary employees. In other words, the occupation of women influences the children's nutritional status since the income will be used to fulfill their family's need, particularly their children. Having a permanent work ensures that the children's foods, for example, the formula milk, is always provided. One's appetite is not only influenced by a feeling to eat, or hunger, but also by the emotion. Children who do not get their mother's affection might lose their appetite as well as obstruct their growth. Thereby, the mother or the babysitter is urged to understand the children's feeling and appetite.

The issue of weight loss is shared among the children due to the lack of women's preparedness in providing breast milk during the weaning period. Women are able to monitor the children's dietary once they start working from home.

This is in line with the results seen in Yudi's research (2008) which reports that in Medan, the better the economic status of a family, the higher the chances to always provide children's foods, such as formula milk. On top of that, a high economy status will also shift the way a woman nurture and raise their children.

A study conducted in Semarang by Himawan (2006) reports that the participation of women in some activities outside their home will put the children at a disadvantage. Women tend to focus on their activity leaving their children somewhat being abandoned at home despite the importance of toddlers period in further shaping a child's health. Also, during the period, the children depend on their parents since they are unable to do things by themselves. Therefore, women should ask for help from their relatives or hire a babysitter to look after their children, including their dietary.

Some of the families with good economic status are also prone to the issue of undernutrition. This blames the condition in which the woman works to fulfill her family needs, and at the same time, she gets children to take care as well as to work on her jobs other than household chores.

3.2.2 The Influence of Women's Knowledge on the Children's Nutritional Status

The results reveal that the null hypothesis is rejected and the alternative hypothesis; this represents the sufficient knowledge that the respondents have. Furthermore, women's knowledge also helps them taking care of their children as well as providing healthy foods to shape the children's nutritional status. To put it simply, an in-depth understanding and knowledge of the women lead to the more efforts to plan a healthy diet for their children.

There are some contributing factors to the insight regarding nutrition that a woman has; among the examples are the social environment aspect as well as the exposure of mass media to the woman. One of the contributing factors of the nutritional issue is the lack of knowledge, skills, and how to apply these on a daily life basis.

This is in line with Himawan's research (2006), this was conducted in Semarang. According to Himawan, the level of one's knowledge regarding nutrition significantly affects the traits and behavioral changes in selecting foods in which such elements further contributes to the nutritional status of the person. The insight regarding nutrition of the women is among factors that shape the children's dietary. This enables the women to consider the nutritional needs of their children since this is important in optimising the children's growth and development. Furthermore, it also affects the way the women select the dietary as well as its quantity of the consumption.

Considering the finding of Himawan's (2006) research, the level of people's knowledge regarding nutrition significantly influence the way they select foods; this ultimately affects their nutritional status. The low nutritional status of a particular area determines the undernutrition rate of a nation.

According to Dewi (2013), it is easier for educated people to obtain, to understand, as well as to process information. On top of that, these people are able to decide every information about health that they have particularly the children's nutritional status. This enables the women to fulfill the nutrients for their children.

3.2.3 The Influence of Traditions and Customs on the Children's Nutritional Status

The term tradition and customs, in the context of this study, refers to the frequency of foods consumed in a day. The results reveal that the null hypothesis is rejected and the alternative hypothesis; this is to show that most of the children eat more than three times which signifies an abnormality. This is because the regular frequency of consumption and diet will affect the children's nutritional status. On the other hand, a lower or even higher

foods consumption can lead to problems, such as undernutrition, malnutrition, and excessive nutrition.

A dietary habit is without question an approach to educate the children; this must be practiced since the childhood. Such an attempt will introduce the healthy dietary and variety of foods for the children as they will practice this habit until they grow up later on. This corresponds to the results seen in Yulius (2009) which states that children's dietary triggers the issue of malnutrition in the target area of Mata community health center, Kendari city in 2009.

Providing healthy foods aims at optimising the children's growth and development. Further, this also helps the body to produce sufficient amount of nutrients to increase and develop the whole genetic potential. Providing healthy foods aims at optimising the children's growth and development. Further, this also helps the body to produce sufficient amount of nutrients to increase and develop the whole genetic potential.

On the other hand, an improper diet and frequency of consumption of foods, e.g., staple, side dishes, vegetable, and fruits in a day trigger the problems of nutrition.

3.2.4 The Influence of Personal Belief on the Children's Nutritional Status

The results reveal that the null hypothesis is rejected and the alternative hypothesis; this represents the condition in which most of the women do not restrict the dietary of their children. Most of the women in the site restrict their children to eat particular kinds of foods for health reason. For instances, some women believe that eating particular foods will cause allergy symptoms in their children.

Sukandar (2007) asserts that such a restriction is due to the people's tradition. Most people do not realize when they start and what makes them have such a habit. Once people follow this habit, they believe that disobeying the rules of the tradition will put them at a disadvantage; they consider it as a punishment for doing such an act. However, such negative impacts are not always accurate; even people do not suffer from any of these.

Some foods are prohibited for children, pregnant women, nursing mothers, or even adolescents. From the perspective of nutrition studies, some of the prohibited foods are nutrient dense foods. However, people do not consume the foods due to the prohibition and the assumption of the risk that they will face if they insist on consuming the foods. This ultimately leads to the nutrition issues around the society, particularly the children.

This is echoing the results seen in Yudi (2008) that most of the society in Medan does not follow the tradition of the prohibition of foods and dietary. People, who live in the same area, for example, the urban society, follow one similar tradition and customs.

In general, foods prohibition is related to people's emotion as women are the ones who are likely to follow the trend; this ultimately affects the dietary of their children.

Culture plays a significant role in shaping the dietary of the people, and it leads to the emergence of a tradition or habit in selecting foods. Some of the healthy foods are prohibited due to the culture, traditions, habits, or customs of a particular society. The nutrition issues can be overcome if people start to realize that such dietary habit is not to be applied on a daily basis.

CONCLUSION

The conclusions of this present study are as follows:

1. The result of *chi-square* test shows the relationship between the women's knowledge and the children's nutritional status. This is revealed by the value of X^2 count 3.905^a and X^2 table 3.84. In other words, X^2 count outnumbers the X^2 table with the probability 0.048. Therefore, the null hypothesis is rejected, and the alternative hypothesis is accepted. In addition, 207 among 300 respondents are working as temporary employees, and the other 93 are the opposite.
2. The result of *chi-square* test shows that women's knowledge influences the children's nutritional status. This is revealed by the value of X^2 count 9.443^a and X^2 table 3.84. In other words, X^2 count outnumbers the X^2 table with the probability 0.005. Therefore, the null hypothesis is rejected, and the alternative hypothesis is accepted. There are 295 out of 300 respondents are in a good category in terms of their knowledge, and the other five are in the poor category.
3. The result of *chi-square* test shows that tradition and customs play a major role in shaping the children's nutritional status. This is revealed by the value of X^2 count 4.417^a and X^2 table 3.84. In other words, X^2 count outnumbers the X^2 table with the probability 0.036. Therefore, the null hypothesis is rejected, and the alternative hypothesis is accepted. It is revealed that 227 among 300 respondents have bad habits and the other 73 are the opposite.
4. The result of *chi-square* test shows that personal beliefs affect the children's nutritional status. This is revealed by the value of X^2 count 0.681^a and X^2 table 3.84. In other words, X^2 count outnumbers the X^2 table with the probability 0.409. This is because the

null hypothesis is accepted and the alternative hypothesis is, however, rejected. The finding represents the 217 out of 300 respondents who follow a tradition of dietary restrictions. On the other hand, the other 83 do not follow the trend.

5. In conclusion, the socio-economy and socio-cultural condition of women plays a significant role in shaping children's nutritional status. Aspects, such as occupation, knowledge, traditions, and customs affect the children's nutritional status. On the other hand, personal beliefs do not play a major role to the nutrition since most people do not follow traditions or customs in terms of dietary.

RECOMMENDATIONS

Recommendations for health services and related stakeholders

1. Stakeholders should consider the socio-cultural aspect in designing further health development programmes, especially on improving people's nutritional status.
2. Workshops and seminars on improving children's nutritional status are necessary to conduct.
3. Stakeholders should equip the health service officers with good communication skills to have a better approach to the society and to raise the awareness and participation of the people.

Recommendation for women

It is recommended for women to always gain information about children's nutritional status from printed or electronic mass media.

Recommendation for further research

Further studies regarding other factors that influence children's nutritional status with more sample and in the broader scope of research are essential. This is also to emphasize the results of other related research.

REFERENCES

Dewi, S. (2013). Gambaran Pengetahuan Ibu Tentang Status Gizi Balita Di Lingkungan Viii Kelurahan Sei Agulmedan [Women's Knowledge regarding Children's Nutritional Status in Lingkungan Viii, Sei Agulmedan District]. *Jurnal. Medan*.

Dinas Kesehatan Kabupaten Bone Bolango. 2015. Profil Dinas Kesehatan Kabupaten Bone Bolango Tahun 2015 [Profile of Health Service, Bone Bolango Regency, 2015].

- Mulyaningsih, F. (2008). Hubungan Antara Pengetahuan Ibu Tentang Gizi Balita dan Pola Makan Balita Terhadap Status Gizi Balita di Kelurahan Srihardono Kecamatan Pundong [The Influence of Women's Knowledge Regarding Children's Nutrition and Dietary on the Nutritional Status of the Children in Srihardono Sub-district, Pundong District]. *Skripsi*. Yogyakarta.
- Sukandar, D. (2007). Studi Sosial Ekonomi, Aspek Pangan, Gizi, dan Sanitasi Petani Daerah Lahan Kering di Lombok Tengah Nusa Tenggara Barat [A Study on the Aspects of Socio-economy, Foods, Nutrition, and Sanitation of the Farmers within Dry Land in Lombok Tengah, Nusa Tenggara Barat]. *Jurnal*. Bogor.
- Supariasa, Bakri, Fajar. (2012). *Penilaian Status Gizi* [Examining Nutritional Status]. Jakarta: EGC.
- UNICEF Indonesia. (2012). Gizi Ibu dan Anak [Nutrition of Women and Children]. *Jurnal*. Jakarta.
- Yudi, H. (2008). *Hubungan Faktor Sosial Budaya Dengan Status Gizi Anak Usia 6-24 Bulan di Kecamatan Medan Area Kota Medan* [The Influence of Socio-cultural Factor on the Children 6-24 Months Old in Medan District, Medan City]. Tesis. Medan

ANALYSIS OF ZINC AND FE IN BLOOD TO CHILDREN OF MALARIA PATIENTS

Laksmyn Kadir¹⁾

¹⁾Public of Health DepartementGorontalo State University

Email : asi_1403@ung.ac.id



Abstract

Malaria threatens public health. This case will give affects the decline in the quality of human resources that can cause various social problems, even economic impact on national resilience. Deficiency of Zinc and Fe can disrupt the immune response to infectious diseases through several mechanisms, ranging from phagocytosis and congenital immune responses to antibody formation and cell-mediated immunity.

The objective of study is to analyze the level of zinc and FE levels of blood of children with Malaria

Methods: Observational Analytic and sampling technique that is by way of Purposive sampling that takes blood of children with malaria which amounts to 40 patients.

Results: The human blood zinc level was 78.43 $\mu\text{g} / \text{dL}$ (± 5.70) normal (80-110 $\mu\text{g} / \text{dL}$) blood levels of malaria patients were 68.88 $\mu\text{g} / \text{dL}$ (± 12.59) normal (80-180 $\mu\text{g} / \text{dL}$). There is a decrease of normal levels found in children with malaria

Conclusion: The acute phase response greatly influences the concentration of many micronutrient status indicator, including ferritin concentration and Zn concentration.

Keyword : Malariae, Zinc, Fe, Children

**THE RELATIONSHIP BETWEEN BEHAVIOR OF GORONTALO PEOPLE IN
CONSUMING FOOD WITH CORONARY HEART DISEASE INCIDENT IN RSUD
PROF. DR. H. ALOE SABOE GORONTALO CITY**

"EDUCATIONAL CHALLENGES AND STRATEGIES OF HIGHER EDUCATION IN HEALTH ACHIEVEMENT OF SDGS 2030"

Herlina Yusuf, Siti Rahma, Edwina R. Monayo, Ismet Habbi



Health and Sport Faculty, Gorontalo University

Abstract

Coronary Heart Disease (CHD) is a disorder of heart function which the heart muscle lacks of the blood supply that caused by coronary artery constriction. Coronary heart disease is influenced by several factors that are factors that can not be changed and can be changed such as consuming food. The aims of this study to determine the relationship of habitual behavior of Gorontalo people in consuming food with the incidence of coronary heart disease in RSUD Prof. Dr. H. Aloe Saboe Gorontalo City.

This research is Analytical Survey with cross sectional design. The population of this study were all patients who came to the heart polyclinic of RSUD Prof. Dr. H. Aloe Saboe Gorontalo City with samples determined by accidental sampling technique . statistical analysis using Chi Square test.

The results showed that there was a correlation between fatty food consumption and CHD occurrence ($p= 0,000$), and there was a relationship between consuming salted food with CHD incidence ($p = 0,032$) and there was a relationship between consuming habits using seasoning flavor and coronary heart disease ($p = 0,029$). It is expected that people more proactive to seek information about health especially related to food pattern and the incidence of coronary heart disease which will help to prevent the happening of coronary heart disease.

Keywords : Coronary Heart Disease, Food consumption habit

Lead Content In Hair and Health Problems at Workers in SPBU (Gas Station) of Gorontalo City in 2017.

Ekawaty Prasetya¹, Herlina Jusuf²

"EDUCATIONAL CHALLENGES AND STRATEGIES OF HIGHER EDUCATION IN HEALTH ACHIEVEMENT OF SDGS 2030" ISrHE
Public Health Departement, State University of Gorontalo, Gorontalo, Indonesia

ABSTRACT

Lead (Pb) is a poisonous heavy metal and able to pollute environment as well as endanger health. Particle of Lead which pollutes air drives from combustion residue of motor vehicle, waste of factory production of alkil Lead and Pb-oxide, combustion of charcoal and other addictive materials. The polluted air enters human body through process of respirations. Concentrate of Lead exposure is influenced by size of particle from lead compound as well as the inhaled air volume. Research samples are workers of SPBU in Gorontalo City to investigate lead content accumulated in workers' body and its influence towards health problems.

This research aims to investigate Lead content contained in hair of SPBU workers and accumulation of Lead metal in workers' body and its influence towards health problems. This is an analytical observational research with cross sectional study approach. The research applies *Atomic Absorbtion Spechtofotometry* (AAS) to analyze specimen.

Finding of hair sample test shows that based on accumulation of Pb exposure towards 48 respondents, 40 of have exceeded the Threshold Limit value namely >2,00 ppm. Then analysis of linear regression shows that value of correlation (R) coefficient between Lead content in hair towards disease complaint is 0,422 with determinant coefficient (R²) for 0,178.

Research conclusion is accumulation of Lead exposure in 83,33% respondents has exceeded the threshold limit value. Correlations between Lead content in hair of SPBU workers in Gorontalo City toward disease complaint is 42,2% and has influence of 17,8% toward health problem of workers. Therefore, owners of SPBU are expected to provide PPE for their workers.

Keywords : Lead, Hair, Worker of SPBU

SUPPLEMENTATION OF SNAKEHEAD FISH EXTRACT TOWARD MALONDIALDEHYDE (MDA) LEVEL IN POST-STROKE PATIENT

Vivien Novarina Kasim¹, Sri manovita Pateda², Veni Hadju³, Nurhaedar Jafar³

¹Nursing Department, Sport and Health Faculty, State University of Gorontalo

²Public Health Department, Sport and Health Faculty, State University of Gorontalo

³Nutritional Department, Hasanuddin University

Stroke affects the metabolic disorders of nutrients caused by increased catabolic hormones that cause hypercatabolism and hyperglycaemia. It is believed that free radical formation and subsequent oxidative damage in the form of lipid peroxidation may be a factor in the cerebral damage secondary to the ischaemia of a stroke patient. The supplement of extract of snakehead fish as an alternative is expected could reduce the effect pasca stroke. Aim of this research is to describe the Malondialdehyde (MDA) level on post-stroke patient, who accepted extract of snakehead fish on their stroke onset. MDA level were measured in 25 post-stroke patient. The minimum level of MDA is 5,99 and the maximum level is 47,6. There is no age difference in level of MDA.

Keyword: snakehead fish, stroke, MDA

THE IMPACT OF LIGHTING INTENSITY ON THE ISSUE OF EYESTRAIN OF KARAWO ARTISANS IN GORONTALO

Reni Hiola¹⁾, Rama Hiola²⁾, Lanto Mohamad Kamil Amali³⁾

^{1,2)}Dosen Jurusan Kesehatan Masyarakat Fakultas Olah Raga & Kesehatan

³⁾Dosen Jurusan Teknik Elektro Fakultas Teknik

"EDUCATIONAL CHALLENGES AND STRATEGIES OF HIGHER EDUCATION IN HEALTH ACHIEVEMENT OF SDGS 2030"



Abstract

Karawo industry refers to a small-scale enterprise and folk art currently developing in Gorontalo province. Women are usually the ones who run this business. Karawo refers to traditional embroidery passed down from generation to generation since the 17th century, in 1713. Generally, a supporting and safe working environment is essential in developing this enterprise and, therefore, boosting the performance and productivity of the artisans.

For instance, a sufficient lighting condition provides a convenient environment for the artisans in their work. This is because a poor lighting will obstruct the productivity and the efficiency of the workers due to health issues, such as eyestrain.

The purpose of this research is to explore the impact of lighting intensity on the issue of eyestrain of Karawo artisans in Gorontalo regency. Methods of research involved observation and reviewing the literature regarding the lighting system of the Karawo craft industries, studies on the respondents relating to the level of the eyestrain through flicker fusion measurer, Snellen chart, questionnaires, and determining the standard of the lighting for the artisans.

The results reveal that all the respondents do not show any symptoms of eyestrain before working; however, there are reports regarding health problems in all respondents (100 percent), i.e., headache, eye irritation, blurring of the vision, and another discomfort around their eyes after working. Furthermore, 26 percent of the artisans working less than two weeks suffer from acute eye strain while chronic eyestrain occurs to those (45 percent) who work for more than two weeks. An intense use of eyes in the Karawo embroidery is because the process requires high accuracy to work on small and soft materials is the contributing factor to the problem. This will get worse if the lighting condition in the working environment is not sufficient to support the work of the artisans.

Keywords: Karawo Artisans, Lighting Intensity

THE INFLUENCE OF CHARACTERISTIC AND MOTIVATION TOWARD PERFORMANCE OF BASIC IMMUNIZATION WORKERS AT PUSKESMAS AT BONE BOLANGO DISTRICT

Rama Hiola¹⁾ Anti Igrisa²⁾

"EDUCATIONAL CHALLENGES AND STRATEGIES OF HIGHER EDUCATION IN HEALTH ACHIEVEMENT OF SDGS 2030"



ABSTRACT

Immunization program is one of several efforts to protect someone from certain diseases which is given to population who are considered as susceptible infected by communicable diseases particularly babies or toddlers. Bone Bolango Department of Health revealed that 11 puskesmas have not yet achieved SPM target of 80% due to several babies have not yet received complete basic immunization or even received it at all. The achievement cannot be separated from nurses or midwives role in basic immunization implementation. This research aims at investigating the influence of characteristic and motivation towards basic immunization workers at Puskesmas of Bone Bolango District.

This is an analytical survey with cross sectional design. Population is 238 people. Samples are nurses and midwives who implement basic immunization at Puskesmas in Bone Bolango amounted to 39 respondents. Data analysis is done through Fisher's exact test using a at 0,05 and confidence level of 95%.

Research findings reveal that individual characteristic; age ($p = 0.082$), education ($p = 0.393$), work duration ($p = 0.590$), and training ($p = 0.459$), do not influence the performance of basic immunization workers ($p \leq 0.05$), while motivation influences the performance ($p = 0.048$). It is suggested that the head of Puskesmas should increase performance of basic immunization workers by giving them motivation such as award or praise toward outstanding officers in doing basic immunization service. It is expected from basic immunization workers to increase their knowledge and skill in doing basic immunization thus error, imprecision, and inaccuracy in immunization implementation can be prevented.

Keywords: Characteristic, Motivation, Performance, Immunization Implementation

Email : hiola.rama@gmail.com

AN ANALYSIS OF FACTOR RELATED TO MALARIA INCIDENT AT ELEMENTARY SCHOOL STUDENTS

LIA AMALIA

(email: lia.amalia29@gmail.com)

Study Program of Public Health Faculty of Health and Sports
State University of Gorontalo
Gorontalo, Indonesia

ABSTRACT

Malaria is an infectious disease caused by parasit of genus *plasmodium*, it is infected to human through bite of female anopheles mosquito and it cannot transmitted to other people directly. Determination of malaria endemicity level in Gorontalo area is done based on Annual Malaria Incidence (AMI) and Annual Parasite Incidence (API) size. AMI percentage of malaria patients in Gorontalo provinsi particularly in District of Gorontalo Utara is 9,3% and its API is 1,54%. Based on standard, this distric is in medium level of endemicity. This research aims to analysis factors related to malaria incidents at elementary school students. This is an observational analytical research with cross sectional study design. Research samples are 105 student from age 7-12 years at SDN 5 Sumalata Timur. Independent variabels are level of parents education, mosquito net use habit and condition of house circumstance. Research date are analyzed by chi-square statistics test with significance of 95% ($\alpha = 0,05$).

Research finding reveals that based on chi-square test, it shows that there is significant correlation between level of parents Education ($\chi^2=8,409$ p value=0,006), mosquito net use habit ($\chi^2=20,114$ p value=0,000) and condition of house circumstance ($\chi^2=24,563$ p value=0,000) with malaria incident, Thus it is suggested to do socialization about malaria incident by using media that is easy to be understood by society particularly those who are with low level of education as well as improve society empowerment in preventing and controlling vectors with keep the cleanliness of environment and healthy life behavior.

Keyword: Malaria, level of parents education, mosquito net use habit and condition of house circumstance

INTRODUCTION

Malaria disease is still a world problem in developing countries. This issue is one of the points discussed and set out in the 2015 Millennium Development Goals (MDGs) agreement on the 6th point on combating HIV/AIDS, malaria and other diseases. Likewise at the 60th World

Health Assembly (WHA) meeting on May 18, 2007 has resulted in a global commitment on the elimination of malaria for every country. Guidance on the implementation of malaria elimination that has been formulated by World Health Organization (WHO) in the Global Malaria Program (Kemenkes, RI 2009).

WHO (2014) recorded incidences of malaria incidence in 2013 of approximately 198 million cases with deaths of approximately 584,000 cases (case fatality rate = CFR = 0.29%). The highest risk of transmission occurs in the African region with a total estimated death of about 528,000 cases (0.32%).

The WHO 2014 report estimates that 3.3 billion people are at risk of being infected with malaria where its 1.2 billion is at risk with Annual Parasite Incidence (API) > 1 per 1000 population. Plasmodium falciparum and vivax are the most common plasmodium found worldwide.

The determination of malaria endemicity level in Gorontalo area is done based on Annual Malaria Incidence (AMI) and Annual Parasite Incidence (API). The value of AMI for malaria patients in Gorontalo Province, especially in Kabupaten Gorontalo Utara is 9.3% and API 1.54%. The national standard of malaria endemicity determination in a region is said to be low if API <1%, AMI <25%, while API 1-5% or AMI 25 - 50% and high endemicity if API > 5% or AMI > 50%. Based on these standards, Kabupaten Gorontalo Utara is located at a moderate level of endemicity

Public Health Department - Sport And Health Faculty - Gorontalo State University

METHOD

This research was conducted at SDN 5 Sumalata Timur. This was an observational analytic study with cross sectional study design. The sample was 105 children aged 7-12 years. All the children were taken of blood and examined malaria microscopically and by Immunochromatographic Test (ICT). Of the total number of students who were 105 children, positive malaria falciparum 79 people (75.2%) and 5 children (6.32%) were detected in the form of gametes. Positive samples counted the number of parasitemia and then the students who tested positive were given treatment with anti-malarial drugs ie Artemisinin Combination Therapies (ACT) and antacids to avoid nausea caused by taking malaria drugs and respondents are parents of children.

Dependent variable in this study is the incidence of malaria, the respondent whose blood test results showed positive results of one or combination of plasmodium malaria from laboratory examination with microscope, while the independent variables in this study are the level of parents education, *mosquito net use habit and condition of house circumstance*.

The level of parents Education is the last formal education level has been completed by the respondent who is categorized to be high if if the respondent

is educated > SMP and low if respondent \leq SMP.

Mosquito net use habit in this research is way to avoid contact or bite of anopheles mosquito at bedtime by using mosquito net. Objective criteria, wear: if wearing bed nets at bedtime or ventilation using wire netting and not wearing, if not wearing bed nets at bedtime or ventilation not using wire netting.

The variable of house environment condition in this research is the circumstances around the respondent's house which consist of: bush and cattle livestock as mosquito breeding place, ditch or ditch as breeding place of malaria mosquito with objective criterion, not qualified if there is one of criteria (there are bushes, there are puddles around the house, and a cattle bar <10 meters away from the house) and qualify if it has a gutter, no puddles around the house and a cattle bar > 10 meters from the house.

The data collecting of parent education level, *mosquito net use habit and condition of house circumstance* is done by interview and direct observation to respondent's house. Data on malaria

incidence, age and sex were taken at the visit register of puskesmas. Data were analyzed using Chi-square test with 95% significance ($\alpha = 0,05$).



RESULTS

Malaria is a highly contagious infectious disease in the tropics and sub-tropics and can be deadly. At least 270 million people of the world suffer from malaria and more than 2 billion or 42% of the population of the earth has a risk of malaria. WHO records annually that no less than 1 to 2 million people die from Anopheles mosquito-borne diseases.

The source of infection for humans is another human who suffers from malaria with no symptoms or clinical symptoms. In endemic areas malaria-infected children have not developed immunity to malaria in their bodies when compared with adults, so the severity of malaria will be more severe. Conversely in areas with low endemicity, adults do not have the same sensitivity and severity as children and migrants from non-endemic areas of malaria.

Table 1. Description of the variables studied (age, gender, level of parents education, mosquito net use habit and condition of house circumstance with malaria incidence in students at SDN 5 Sumalata Timur

Variable	Malaria	Not Malaria	Amount
Age			
7-9 years	17 (21,5%)	5 (19,2%)	22 (20,9%)
10-12 years	62 (78,5%)	21 (80,8%)	83 (79,1%)
Gender			
Women	30 (38,0%)	9 (34,6%)	39 (37,1%)
Man	49 (62,0%)	17 (65,4%)	66 (62,9%)
Level of Parents Education,			
SD	21 (26,6%)	4 (15,4%)	25 (23,8%)
SMP	46 (58,2%)	11 (42,3%)	57 (54,3%)
SMA	11 (13,9%)	10 (38,5%)	21 (20,0%)
PT	1 (1,3%)	1 (3,8%)	2 (1,9%)
Mosquito Net Use Habit			
Not wear	68 (86,1%)	11 (13,9%)	79 (75,2%)
Wear	11 (42,3%)	15 (57,7%)	26 (24,8%)
Condition of House Circumstance			
not eligible	63 (79,7%)	19 (33,3%)	35 (33,3%)
qualify	16 (20,3%)		
Jumlah	79 (75,2%)	26 (24,8%)	105 (100,0%)

Table 1 shows that out of 105 samples, there are 79 students (75.2%) who are malaria positive and 26 students (24.8%) are not malaria. Based on the age variable, it was found that both malaria and non malaria, the age group was 10-12 years old (62,5%) and 21 students (80,8%). Based on sex, malaria-positive and non-malarial students, male is the most gender, 49 students (62,0%) and 17 students (65,4%).

Based on *level of parents education* showed that malaria positive and non malaria, low education level (\leq SMP, Junior high school) is the highest level of education, each of 67 students (84.8%) and 15 students (57.7%). Based on data

analysis using Chi-Square statistical test in table 2 then χ^2 count 8.409 > value χ^2 table 3,841. Because χ^2 count > χ^2 table and p value (0.004 < α 0.05) this means that H0 is rejected means there is significant relation between level of parents education and malaria incidence.

Based on mosquito net use habit, it was shown that out of 79 malaria positive students who did not use bed nets as much as 68 students (86,1%) and those who did not have malaria, were mostly distributed with 15 students (57,7%) while the most malarial homes in the neighborhood have 63 households (79.7%) and the non-malaria has the most eligible environment

with 19 students (73.1%). Based on data analysis using Chi-Square statistical test in table 2 then χ^2 count 20,114 > value χ^2 table (3,841). Because χ^2 count > χ^2 table

and p value (0,000 < α 0,05) this means that H0 is rejected means there is significant relation between mosquito net use habit and malaria incidence.

Tabel 2 Result of analysis of Independent Variables and Dependent Variables

Variable	χ^2	p value
level of parents education,	8,409	0,004
mosquito net use habit	20,114	0,000
condition of house circumstance	24,563	0,000

DISCUSSION

1. Correlation between level of parents education with malaria incidence

The results of analysis using Chi-Square statistical test obtained χ^2 count 8.409 > value χ^2 table 3,841. Since χ^2 count > χ^2 table and p value ($0,000 < \alpha 0.05$) this means that H_0 is rejected means there is significant correlation between level of parents education with malaria incidence.

The level of education affects the knowledge of a person, in general, people who have a high level of education easier to know about malaria because it is easier to understand information about malaria. The results showed that malaria incidence occurred in many samples with poorly educated parents. This shows the low knowledge of parents about malaria

Education is a process that will result in a change in target behavior that is expected by a particular organization / institution by providing a formal education that has received someone will increase the power of reason and the basic development of reasoning power allows one to accept motivation (Notoatmodjo, 2007).

This study is in line with research conducted by Indarti (2010) where low-educated people are at high risk for contracting malaria. In educational theory is a process that will result in a change in target behavior that is expected by a particular organization by providing formal or informal education to its members.

2. Correlation between mosquito net use habit with malaria incidence

The results of data analysis using chi-Square statistical test showed a significant correlation between the mosquito net use habit with the incidence of malaria with the value of χ^2 count 20,114 > value χ^2 table 3,841. Therefore χ^2 count > χ^2 table and p value value ($0,000 < \alpha 0.05$).

Based on interviews with respondents about the habit of wearing bed nets each before bed that suffered from malaria and not wearing bed nets as much as 68 children (86.1%), they reasoned that children feel hot / hot when using bed nets during sleep and also the economic status of the community low so that the provision of mosquito nets is not a top priority in the fulfillment, on the other hand they reasoned not used to use bed nets while

Public Health Department - Sport And Health Faculty - Gorontalo State University

sleeping while if using other anti mosquito alternatives, they feel disturbed by the smoke and also the cost to be spent for the procurement of anti-mosquitoes.

This research is in line with the research conducted by Datau (2010) where an unqualified environment is one of the factors causing the incidence of malaria.

3. Correlation between condition of house circumstance with malaria incidence

Based on data analysis using Chi-Square statistical test by value χ^2 count 24,563 > value χ^2 table 3,841. Since χ^2 count > χ^2 table and p value value (0,000 < α 0.05) this means that H0 is rejected means there is a significant correlation between condition of house circumstance with malaria incidence.

In this study obtained respondents who are high risk of having a home environment that does not meet the requirements of 63 samples (79.7%). Based on the results of the research with respondents, the condition of the respondent's living environment still does not meet the requirements due to their home environment there are bushes around the house, do not have ditch and water ditok not flowing.

The presence of thick shrubs will reduce sunlight entering / penetrating the soil surface, so that the surrounding environment will be shady and humid. This condition is a good place to rest for the mosquitoes and also the mosquito breeding place under the bush there is stagnant water.

Stagnant household waste can be a breeding ground for mosquitoes. Female mosquitoes will lay eggs in stagnant water. These eggs will develop into larvae and then change into adult forms within 10 days. So that the number of mosquito population around the house increases and causes the families living in the house that there are ditches around the house have a risk for the occurrence of transmission of malaria compared with families who live in the house that there is no ditch / ditch around it.

CONCLUSION

Based on the result of the research, it can be concluded that: there is a correlation between parent education level, habit of wearing mosquito net and environmental condition of house with malaria incident on student of SDN 5 Sumalata Timur Kabupaten Gorontalo Utara.

Public Health Department - Sport And Health Faculty - Gorontalo State University

SUGGESTION

Demographic factors such as age, and education level associated with malaria incident by using media that is easy to be understood by society particularly those who are with low level of education as well as improve society empowerment in preventing and controlling vectors with keep the cleanliness of environment and healthy life behavior.

REFERENSI

- 1) Das R, Khan PN, Amir A. Epidemiologi Assessment of The Tren of Malaria in Rural Western U'P. *Indian J Community Med.* 2004;29 (3): 134-135
- 2) Datau, S. 2010. *Faktor-faktor yang berhubungan dengan kejadian malaria di wilayah Puskesmas Paguyaman Kecamatan Paguyaman Kabupaten Boalemo Tahun 2010.*
- 3) Depkes RI, *Epidemiologi Malaria*, Direktorat Jenderal PPM-PL, Departemen Kesehatan RI, Jakarta 2003.
- 4) Dinas Kabupaten Gorontalo Utara, 2016, data penderita malaria, Gorontalo Utara
- 5) Indarti, D. N, 2010. *Faktor-faktor yang berhubungan dengan kejadian malaria pada pasien rawat inap di BLUD.RSU.Dr.M.M.Dunda Kabupaten Gorontalo Tahun 2010.*
- 6) Kementerian Kesehatan RI. Epidemiologi Malaria di Indonesia. *Buletin Jendela Data dan Info Kesehatan.* 2011
- 7) Notoadmodjo, S. 2007. "*Perilaku Kesehatan*". Rineka Cipta. Jakarta.
- 8) Puskesmas Sumalata Timur, 2017, *Data penderita malaria*, Gorontalo Utara.
- 9) Rahayu, S, M, 2010. *Faktor-faktor yang berhubungan dengan kejadian malaria di wilayah Puskesmas Paguyaman Kecamatan Paguyaman Kabupaten Boalemo Tahun 2010.*

***RISK ASSESSMENT OF HEAVY METALS EXPOSURE ON OREOCHROMIS
MUSAMBICUS IN LIMBOTO LAKE GORONTALO PROVINCE.***

NUR AYINI S. LALU.

(email : nurayini.s.lalu@gmail.com)

***Study Program of Public Health Faculty of Health and Sports
State University of Gorontalo
Gorontalo, Indonesia***

ABSTRACT

The aim of the research was to find out the health risk on community around Limboto Lake because of heavy metal of mercury and cadmium in *Oreochromis musambicus*.

The research used an observational design with environmental health risk analysis. The sample of lake water consisted of three stations and human sample consisted of 100 people selected using certain criteria. the methods, and environmental the data were interview, direct measurement of respondents, and environmental observation. The analysis was conducted by using ERHA method with Excel program.

The results of the research indicate that the highest average concentration of mercury and cadmium in *Oreochromis musambicus* is in Podutuma village, while the average concentration of mercury (Hg) in the water of Limboto Lake have exceeded quality standard of ISO 2011. The average risk level of *Oreochromis musambicus* consumption containing mercury indicates the value of more than 1 ($RQ > 1$). This means that *Oreochromis musambicus* consumption is not safe an risk causing health problem. Meanwhile, the average risk level *Oreochromis musambicus* consumption containing cadmium indicates the value of less than 1 ($RQ < 1$), this means that *Oreochromis musambicus* consumption. But this is the same fish, the heavy metals Hg and Cd remain risk of health problems if taken with excessive frequency in the long time.

Risk management can be done by lowering the mercury and cadmium level, controlling intake rate, and decreasing exposure duration.

Keyword : Environmental Health Risk Assessment, Mercury, Cadmium, Limboto Lake

Effects of Self Efficacy and Collective efficacy on prevention Behavior of Community with Hypertension in Gorontalo Province

"EDUCATIONAL CHALLENGES AND STRATEGIES OF HIGHER EDUCATION IN HEALTH ACHIEVEMENT OF SDGS 2030"

By ; Irwan



Departement Of Public Health Gorontalo state University

ABSTRACT

Basic Health Research (Riskesdas) in 2007 showed that the prevalence of hypertension in the population of Indonesia, by 30.3%. The prevalence of hypertension in the province Gorontalo by 31.5%, higher than the national prevalence. The results in Gorontalo in 2010 showed that the prevalence of hypertension in the Gorontalo city 38%. Generally less influenced people's behavior in the prevention of hypertension. Unfavorable behavior as much as 72% among those with hypertension and poor behavior in people who are not hypertensive by 48%. The purpose of this study to influence analysis Collective Self-efficacy and efficacy against hypertension prevention behaviors. Methods of observational analytic studies, case control study design, a large sample of 180 people with a history of hypertension and offspring two stage cluster sampling that. Self efficacy results showed a significant effect on self-regulation, with a path coefficient of 0,276 and T-Statistic value of 3,108. Collective efficacy positively and significantly related to self-regulation, with a path coefficient of 0,275 and a value of 12,289 T-Statistic. Self-regulation and a significant positive effect on behavior prevention, with a path coefficient of 0,887 and T-Statistic value of 41,962. Hypertension prevention behaviors positive and significant effect on hypertension, with a marked positive path coefficient of 0,955 with T-Statistic value of 422,475. Conclusions Self-efficacy and collective efficacy directly affects self-regulation, then the effect on hypertension prevention behavior, it is advisable to have a policy of intensive health promotion strategies to people in Gorontalo

Keywords: Self-efficacy, Collective efficacy, behavior prevention, hypertension

DETERMINANT ANALYSIS MALE PARTNER INVOLVEMENT IN PREVENTION OF HIV TRANSMISSION FROM MOTHER-TO-CHILD PROGRAM (PMTCT) IN PUSKESMAS JUMPANDANG BARU MAKASSAR

Sabrina Nadjib M

Department of Public Health, Gorontalo State University

E-mail: sabrina_epid@yahoo.com

ABSTRACT

Some studies showed that involving the male partner in the PMTCT program can increase the level of participation of pregnant women to access PMTCT services. The aim of the study was to analyze factors affecting the involvement of male partners in the PMTCT program at JumpandangBaruPublic Health Center of Makassar from 2008-2014. The research was an analytical observational study with mixed methodology design. The population of the study were all male partner living in the Makassar city. Samples of the study were 31 male partners of HIV-positive pregnant women in Jumpandang Baru health center of Makassar recorded in the medical record data of PHC 2008-2014. Data were analyzed by chi-square test. The results of statistical analysis showed the variables that influence in terms of male partner involvement is stigma ($p = 0,005$). While perception ($p = 0,440$) and marital status ($p = 0,191$) had no effect in male partner involvement. High stigma in society, lack of knowledge and information gained on PMTCT is a factor inhibiting the involvement of male partners in the program..

Key words : PMTCT, male partner, stigma, perception, marital status

PRELIMINARY

HIV infection in pregnant women can threaten the lives of mother and baby. Over 90% of HIV-infected children, mother-to-child HIV transmission (MTCT) during pregnancy, during labor and breastfeeding (Judarwanto, 2012). Transmission of HIV from mother to child can be prevented by the prevention of mother-to-child transmission of HIV (PPIA) which is part of the series of efforts to control HIV-AIDS (Kemenkes-RI, 2012). Since 2007, prevention of mother-to-child HIV transmission has been carried out on a limited scale. Until 2008 PPIA services have been provided as many as 30 services, where the number of pregnant women who took HIV test as many as 5,167 people where 1,306 (25%) of them infected with HIV, but only 165 people or 12.6% who received antiretroviral drugs conducted in 30 units service (Nasution et al., 2012). HIV prevalence in pregnant women is projected to increase from 0.38% (2012) to 0.49% (2016), and the number of HIV positive pregnant women requiring PPIA services will also increase from 13,189 in 2012 to 16,191 in 2016 (Kemenkes-RI, 2009).

Until the end of 2011, PPIA services in Indonesia have been available in 90 referral hospitals located in provincial capitals and major cities and have been accessed by 1,862 women with HIV in Indonesia. In Makassar, the development of HIV / AIDS services in the health sector, HIV-AIDS Voluntary Counseling and Testing (VCT) services are conducted at hospitals and community health centers. PPIA clinic can be done at Wahidin Sudirohusodo Hospital, Labuang Baji Hospital, Puskesmas Jumpandang Barudan and Kassi-Kassi Public Health Center (Mutthalib, 2011).

Implementation of programs that have been proclaimed in the National Guidelines on HIV Prevention from mother to child have two important activities of several implementations, namely community mobilization and husband involvement (Kemenkes-RI, 2012). The involvement of male partners intended to support their female partners / pregnant women to come to maternal and child health services, and to help make informed decisions about HIV. The multiple benefits of involving couples in PPIA programming services have been elaborated in numerous studies. However, some studies show the involvement of male partners who are generally low, which can have a negative impact. In the research journal by Byamugisha et al (2010), in Eastern Uganda revealed that the majority (74%) had low male partner involvement indexes and only 5% of men accompanied their partners to antenatal clinics. Barriers to male partner involvement in PPIA programs are associated with poor health systems, socio-economic factors and local cultural beliefs. The most relevant is the social perception of antenatal care and PPIA as a female activity, and it is unacceptable for men to be involved (Morfaw et al., 2013). This study aims to analyze the factors that influence the involvement of male partners in the PPIA program at Puskesmas Jumpandang Baru Kota Makassar in 2008-2014.

MATERIALS AND METHODS

Research sites

The location in this research is at Puskesmas Jumpandang New Makassar City. Puskesmas Jumpandang Baru is one of Puskesmas that has Harm Reduction and PPIA services in prevention and prevention of HIV and AIDS especially in Makassar city area. The study time was conducted from July to October 2014.

Public Health Department - Sport And Health Faculty - Gorontalo State University

Design and Variable Research

This research is an observational analytic study using Mixed Methodology design that combines quantitative and qualitative research with Embedded Concurrent strategy. The quantitative method using cross-sectional design is intended to study the relationship between predisposing factors, supporting factors and drivers of male partner involvement in PPIA utilization. Qualitative method is intended to obtain more in-depth and accurate information that is indepth interview about the determinants obtained against the involvement of male partners.

Population and Sample

The population in this study were all male partners of HIV positive pregnant women who live in the area of Makassar. The sample in this research is male partner who live in Makassar city which recorded in medical record data of Puskesmas Jumpandang Baru year 2008-2014, has a clear and affordable address that is 31 people. The male couple who took part in the 4 person interview. There are also other key informants such as health workers, peer support group supporters, and wives

RESULTS

Based on table 1 it can be seen that the highest age group of respondents in the age group of 26-35 years is 21 people (67.7%), the highest education frequency in the respondents is high school as many as 21 people (67.7%), and most respondents work as 17 private employees (54.8%). Still in the same table, as many as 48.4% or 15 respondents whose marriage age is under five years and 67.7% or 21 respondents admitted had never been married before. Based on the frequency of HIV status, it was observed that out of 31 respondents, there were 28 people or 90.3% who were HIV positive, and only 3 people (9,7%) were HIV negative.

The data in table 1 also shows that 58.1% of male partners are involved in the PPIA program and 41.9% are not involved in PPIA. Bivariate analysis with "Chi-Square Test" is done to determine the relationship between independent variable and dependent variable. Based on the results of bivariate analysis in table 2 shows that there are 73.7% of respondents who have sufficient level of knowledge related to HIV-AIDS and PPIA and are involved in PPIA program.

Table 1. Distribution of Respondent Characteristics at Puskesmas Jumpandang Baru Kota Makassar			
Characteristics of		n	%
Group	< 26 tahun	1	3,2

Age	26-35 tahun	21	67,7
	35-45 tahun	9	29,0
Education	Tamat SMP	3	9,7
	Tamat SMA	21	67,7
	Tamat PT	7	22,6
Work	Karyawan swasta	10	32,3
	Wiraswasta	17	54,8
	Buruh	3	9,7
	Satpam	1	3,2
Age	< 5 tahun	15	48,4
	5-10 tahun	10	32,3
	>10 tahun	6	19,4
Marital	Ever been married	10	32,3
History	Has never been married before	21	67,7
HIV status	Positif	28	90,3
	Negatif	3	9,7
Involvement	involved	18	58,1
	Not involved	13	41,9

Source: Primary Data 2014

The result of bivariate analysis in table 2 on the relationship of stigma variable and male partner involvement showed that the respondents involved in PPIA as much as 85,7% got negative stigma and 35,3% got positive stigma. The results of statistical test analysis with chi square test obtained p value of 0.005. Because the p value <0.05 then this means there is a relationship between the stigma with the involvement of male partners in the PPIA program. Respondents who received positive stigma revealed that they did not disclose their status even to the family.

"You. Parents know my status. His family is also my wife nda know. Ordinary ji I follow if there is a family event. Ka is not there ji know. Nda dare I ka cau know ". (SY, 29 years old)

"... my family is the same family as you know the status of ta. So they keep their ordinary attitude. "(AA, 32 years).

Public Health Department - Sport And Health Faculty - Gorontalo State University

Table 2. Relation of Independent Variables with the involvement of male partners in PPIA program at Puskesmas Jumpandang Baru Makassar in 2008-2014

Variable	Involvement male partner				Amount		Test results
	Involved		Not Involved		n	%	CI =
	n	%	n	%			95%
Stigma							$p =$
Negatif	12	85,7	2	14,3	14	100	0.005
Positif	6	35,3	11	64,7	17	100	
Persepsi							$p =$
Positif	10	52,6	9	47,4	19	100	0.440
Negatif	8	66,7	4	33,3	12	100	
Marital status							$p =$
Married	12	50,0	12	50,0	24	100	0.191
Live together but not married	6	85,7	1	14,3	7	100	

Source: Primary Data 2014

Perception is the assessment of the male partner against the benefits of the PPIA program for the prevention of mother-to-child transmission of HIV. Based on Table 3 it can be seen that as many as 66.7% of respondents thought that PPIA programs were not useful but they still decided to get involved. Meanwhile, 52.6% of the respondents involved rated that PPIA was beneficial to them and their partners. The results of statistical test analysis with chi square test obtained p value of 0.440. Because $p > 0,05$, this means there is no relationship between perception and male partner involvement in the PPIA program. Although there are people who think that PPIA is not useful, but in general the initial impression of respondents when visiting PPIA clinic is quite good. This is because the service and health workers are friendly with them.

"The year 2010 has never ma to the health center for VCT. Time to join this program, given ki counseling together. I'm my wife. The results of my wife's test is also given the same ji ji me. If the VCT is good at all the nurses are the same doctor. Good ki Pelayanannya if the health center here ". (SY, 29 years).

Marital status is the identity of respondents and their current spouses are categorized into two groups: those already married and living together but not married. Based on Table 2 it can be seen that there are 85.7% of respondents who live together but are involved in the utilization of PPIA services. As for the respondents and their spouses, there is a similar presentation to the involved and not involved in the utilization of PPIA service that is 50%. The results of statistical test analysis with chi square test obtained p value of 0.191. Because the $p > 0,05$ then this means there is no relationship between marital status with the involvement of male partners in the PPIA program.

In general, respondents and their partners already know their HIV status. One of the respondents who lived with her partner but did not marry replied that her partner and he already knew each other's status.

"My girlfriend also used to have her husband. Her dead husband had HIV. so he was infected from his first husband. now I am the same as he lives together. We also already know the status (HIV) ta ". (HI, 32 years old).

DISCUSSION

Male partner involvement is an important part of an effective PPIA intervention. Involving male partners in PPIA services has been shown to increase community acceptance and increase support to women or their spouses in following PPIA services (Tshibumbu, 2006).

The involvement of male partners referred to in this study is the readiness of men to attend HIV counseling and testing with their spouses, providing support in obtaining ARVs and adhering to antiretroviral therapy, and supporting wives in choosing options for feeding their babies. The majority of respondents in this study had known that HIV positive mothers could transmit the virus to their children either in the process of pregnancy, delivery or breastfeeding (93.5%). But there are still 19.4% of respondents who think that HIV virus can not be transmitted during pregnancy. The results of indepth interviews also show that respondents obtained HIV and AIDS related knowledge from friends, PLHIV companions or television and newspapers. Information on HIV-AIDS and PPIA from women's wives / spouses, health workers, NGOs and mass media, especially television and newspapers, can be an effective medium for increasing knowledge about male involvement in PPIA.

Public Health Department - Sport And Health Faculty - Gorontalo State University

Stigma is a negative judgment addressed to a person because of a perceived deviant behavior. This stigma is strongly attached because the people still hold firmly the moral values, religion

and culture or customs of the eastern nation (Indonesia) where the society has not or does not justify the relationship outside of marriage and sex with multiple couples (Nugroho, 2010). Negative stigma in this research is defined as low stigma obtained or less respondents get stigma so they remain willing to engage in PPIA program with their partner. The positive stigma means high stigma in the respondents or often they get stigma so decided not to get involved in the PPIA program.

The results showed that 85.7% of respondents involved in the PPIA get negative stigma and 35.3% who get positive stigma. Meanwhile, for respondents not involved in PPIA service, 14,3% got positive stigma, and 64,3% got negative stigma. The result of statistical test analysis with chi square test obtained p value equal to 0,005. Because the value of $p < 0.05$ then this means there is a relationship between stigma with the involvement of husband / spouse in the utilization of PPIA services.

This is in line with research conducted Tshibumbu (2006) is one of the most common reluctance for husbands in using PPIA services that is afraid if people know that it turns out he is also HIV positive. This reluctance is closely related to shame and is not prepared for the discrimination / stigma of society.

The results of a study by Katz et al (2009) in Nairobi show that as many as 99% of male respondents in this study think that VCT should be offered to pregnant women and then offer HIV testing for men and their partners is preferred to offer it to men male only. Only 84 (27%) of men who visited antenatal clinics said they would prefer HIV testing elsewhere, 63 (75%) preferred testing at special HIV screening sites and 14 (17%) in their workplaces.

Based on the results of indepth interview, respondents revealed that the stigma not only they get from the surrounding environment but also from their workplace. As many as 87.1% of respondents replied that they had never been fired from their previous jobs because they had opened their status.

"A close family who knows our status (HIV). But if there are friends some friends know. I also never told my friends at the office. If they happen to see me again taking medicine, I say I'm sick again. But they also did not find out I was taking any medication ". (HF, 36 years old).

Respondents did not open their status at work. They feel safer to hide their status and as ODHA. This is because the stigma of the social environment and workplace makes them anxious to discriminate both to themselves and to their wives and children.

Perception is a process arising from the existence of activities that can be felt by an object (Wahyuni, 2012). Given that the perception of each person to an object will be different, therefore the perception has a subjective nature. The perception referred to in this study is the interpretation of the situation and not a correct record of the situation in this case the individual assessment of the benefits of PPIA service program for the prevention of mother-to-child transmission of HIV.

The result of statistical test analysis with chi square test ($p > 0,05$) shows that there is no relationship between perception with husband's involvement

"Usually if you take medicine for a wife. The wife of Ji is also the more consul with the doctor at the puskesmas. "(HF, 36 years).

".. not often you too. Especially if check in midwife. Kan usually mothers ji who go. Mereka also better understand that ji. "(HI, 32 years).

One of the most relevant variables is the social perception of antenatal services and PPIA that are seen as women's activities. This perception is then unacceptable to men so they are reluctant to engage in PPIA services. Perception is individual, because perception is an integrated activity within the individual, then what is in the individual will participate actively in the perception. The individual experience is not the same, so in perceiving a structure, the result of perception may be different from one another because it is very subjective (Adelekan et al., 2014).

In this study, although there are still respondents who have a perception that PPIA services are not useful, but they still decide to engage with their partners. This is inseparable from the understanding where the perception of a person is influenced by frame of reference obtained from education, observation, or reading and field of experience, ie experiences that have been experienced that can not be separated from the surrounding environment. The formation of perception is strongly influenced by the information or stimuli first acquired.

Marriage is an emotional and legal bond or commitment between a man and a woman that is interwoven for a long time and involves the economic, social, spouse, physical, and sexual relationships. See the relationship between marital status and the involvement of male partners in the PPIA , there are 58.1% of unmarried respondents but still to be involved in the utilization of

PPIA services. As for the respondents who are married status, seen the same presentation for the involved and not involved in the utilization of PPIA services that is 50%.

The result of statistical test with chi square test ($p > 0,05$) shows that there is no relationship between marital status and male partner involvement in PPIA service utilization. This is not in line with research conducted by Ditekemenet al (2011), which showed a greater involvement 2 times in monogamous couples and 1.6 more in couples living together but not married. Unlike the results of the study shown by Nkuoh et al (2010), men in Cameroon who are in marriage polygamy actually shows greater involvement in VCT in ANC which is one part of PPIA services.

In a study conducted at Puskesmas Jumpandang Baru, researchers found that of 31 respondents, some of them admitted that they have been married more than once.

".. her dead husband had HIV. so he was infected from his first husband. Now I am the same as he lives together. We also already know the status (HIV) ta. "(HI, 32 years).

They acknowledge that their current wife is the second wife. The research results do not indicate a relationship between marital status and the involvement of male partners, because for respondents who choose not to marry, they are still willing to engage in PPIA programs with their partners.

CONCLUSIONS AND SUGGESTIONS

Based on research on male partner involvement in PPIA program, the researcher can conclude that the stigma variable has a significant relationship with the involvement of male partner in PPIA program. While for the variable perception and marital status do not have a significant relationship to the involvement of male partners in the PPIA program. Barriers to male partners' involvement in PPIA are not only due to individu factors, but also because of their outside factors such as socio-cultural and access to health services.

Researchers are then expected to develop more in-depth and comprehensive research on male partner involvement, especially for serodiscordant couples. For male partners

THANK-YOU NOTE

The authors would like to thank the Head of Puskesmas and all employees of Puskesmas Jumpandang Baru Kota Makassar as well as the Peer Support Group supporters who have assisted the implementation of this research.

REFERENCE

- Adelekan L. *et al.* (2014). Married Men Perceptions and Barriers to Participation in the Prevention of Mother-to-Child HIV Transmission Care in Osogbo, Nigeria. *Journal of Sexually Transmitted Diseases*.
- Byamugisha R. *et al.* (2010). Determinants of male involvement in the prevention of mother-to-child transmission of HIV programme in Eastern Uganda: a cross-sectional survey. *Reproductive Health*, 7.
- Ditekemena J. *et al.* (2011). Male partner voluntary counselling and testing associated with the antenatal services in Kinshasa, Democratic Republic of Congo: a randomized controlled trial. *International Journal STD AIDS*, 22: 165-170.
- Judarwanto W. (2012). HIV Mengancam anak Indonesia. Diakses 31 November 2013. Available from: <http://www.depkes.com>
- Katz D. *et al.* (2009). Male perspectives on incorporating men into antenatal HIV counseling and testing. *PLoS ONE*, 4.
- Kemendes-RI. (2012). *Pedoman Nasional Pencegahan Penularan HIV dari Ibu ke Anak (PPIA)*. Jakarta: Kementerian Kesehatan Republik Indonesia.
- Kemendes-RI. (2009). *Laporan PPIA*. Jakarta: Kementerian Kesehatan Republik Indonesia.
- Morfaw F. *et al.* (2013). Male involvement in prevention programs of mother to child transmission of HIV: a systematic review to identify barriers and facilitators. *Biomed Central*, 2.
- Mutthalib N. (2011). *Faktor yang berhubungan dengan Pemanfaatan Pelayanan PPIA di RSP.I Jumpandang Baru Tahun 2011* (Tesis). Makassar: Universitas Hasanuddin.
- Nasution B. *et al.* (2012). Kualitas dan Rekomendasi Perbaikan Layanan PPIA Bagi Perempuan Terinfeksi HIV di Empat Kota di Indonesia. Diakses 10 Desember 2013. Available from: <http://www.ippi.or.id/penelitian-ipi-terkait-program-pencegahan-penularan-hi...%E2%80%8E>.
- Nkuoh G. *et al.* (2010). Barriers to men's participation in antenatal and prevention of mother-to-child HIV transmission care in Cameroon, Africa. *J Midwifery Womens Health*, 55: 363-369.
- Nugroho. (2010). *Catatan Kuliah Ginekologi dan Obstetri (Obsgyn)*. Nuha Medika, Yogyakarta.
- Tshibumbu D. (2006). Factors Influencing Men's Involvement in Prevention of mother-to-child transmission (PPIA) of HIV programmes in Mambwe District, Zambia. Diakses pada tanggal 5

Januari 2014. Available from: <http://www.k4health.org/toolkits/zambia-hivprevention/factors-influencing-mens-involvement-prevention-mother-child>.

Wahyuni Y. (2012). *Determinan Persepsi Ketidakcukupan ASI (PKA) pada Ibu yang Memiliki Bayi di Wilayah Kerja Puskesmas Cicantayan Kabupaten Sukabumi Tahun 2012* (Skripsi). Jakarta : Universitas Indonesia.

DISEASES OF JEMBRANA IN BALI CATTLE IN GORONTALO

¹Tri Ananda Erwin Nugroho, ²Nibras K. Laya, ³Syam Kumaji, ⁴Asmarani K., ⁵Peny Humaida

Jurusan Peternakan^{1,2}, Fakultas Pertanian, Jurusan Biologi, F.MIPA³ - Universitas Negeri Gorontalo

Fakultas Kedokteran Hewan, Universitas Gadjah Mada^{4,5}

ababil.nugroho@gmail.com

Abstract

This research is a basic research to diagnose jembrana disease in Bali cattle in Gorontalo. This needs to be done because the symptoms of sweat have occurred in Bali cows in Gorontalo. Diagnosis of enforcement needs to be done to ensure the existence of jembrana disease so that the development of bali cattle in Gorontalo is not hampered by this disease. Known jembrana disease can be because it canmenimbulkan death and disrupt the productivity. Cow's blood samples are taken from areas where Balinese cows have experienced blood sweat symptoms. Blood samples were taken from the jugular vein using a sterile venoject and accommodated on a vacuum tube containing EDTA anticoagulants. Blood samples were then extracted using Trizol RNA RNA virus. The one step reaction of RT PCR uses the advanced primer (F3) and backward (B3) of the Jembrana virus gag genes. Positive control using pGEX-CA plasmid that has been inserted by the gene gag-ca isolat Tabanan. Visualisai results of RT PCR seen using gel electrophoresis. Samples showing the amplification of the gag gene with a length of 211 were reported to be positively infected with the Jembrana virus. The resulting result, there is a band result in size 211 bp which is similar to the positive control of jembrana virus. It can be seen from 4 samples tested there is 1 positive blood sample containing jembrana virus. The results showed the presence of jembrana disease in Bali cattle in Gorontalo.

PROTEIN ANALYSIS OF TILAPIA FISH FLOUR

Lilik Hidayanti, SKM, MSi¹⁾ Sri Maywati, SKM, MKes²⁾

^{1,2} Faculty of Health Science, University of Siliwangi, Tasikmalaya, Indonesia

Email : lilikhidayanti@unsil.ac.id

Email : srimaywati@unsil.ac.id

Abstract Tilapia fish that is resulted from inland fishery can be used as a content of a complementary food of breast milk. Complementary food from Tilapia fish can increase of child body weight because it have high of non allergenic protein. This protein is very important to support babies's life especially in 1000 days of early life that is started from the pregnancy period to the child's second birthday. If the child suffered malnutrition in this period, like stunted, wasted, and other deficient of micronutrient causes permanent damaged that can not be repaired. The aim of this research was analyzing protein content in the tilapia flour. The steps of this research were making tilapia fish flour and analyzing of protein content. BPTBA LIPI Gunung Kidul was a place that this research activity was done. The result showed rendemen of Tilapia was 15 %. The result of kjeldahl analysis were showing that protein content of tilapia fish flour was 77,73, protein content of green bean flour was 31,8, and protein content of egg soybeen fermented flour was 52,4.

Key words : Under two years child, complementary food of breast milk, Tilapia fish

INTRODUCTION

Under two years of life are renowned as a golden period of the life cycle of human being or often be known as windows of opportunity period. This period is also renowned as a period of 1000 days of early life that influence quality life of human being in the future. Therefore, suffering of undernutrition in this period can decrease of quality of human life. In the last, this condition can be made worse impact for national competitiveness. Under two years children need other foods intake beside of breast milk. This food is called complementary food of breast milk. Nutrient in the complementary food of breast milk must enough to support of daily requirement of child. If it does not enough that it cause faltering of growth and brain development disorder. Actually, under two years children are still getting breast milk for their food intake, but it is not enough to fulfill their nutritional requirement so the children need the other solid food. In consequence of that case, giving additional food to recovery of under nutrition is a program that is given by government. The additional food for under two years children should be in form of complementary food of breast milk.

According Riskesdas (2013), there are still 4,6 million children (19,6%) suffering of undernutrition in Indonesia. There is increasing number of undernutrition if it compare with years of 2017 (17,9%) (Kemenkes, 2014). Under nutrition is caused by household food insecurity (Britta Mullany, *et al*, 2012) that cause decreasing of quantity and quality of food intake (Wynand C.J. Grobler, 2014). This case unfortunately occur in Indonesia where the land has a high of fertility and also a huge of natural resources. Abundant of products of agriculture, plantation, landship and marine fisheries that is produced by Indonesia can be a locally food with a big of nutrition ingredient and easy to get (Harmayani, 2013).

Inland fishery is one of the big commodity that can be easily to get in Indonesia. Non allergenic protein in fish is very good for under two years children so it can be made to be a

complementary food of breast milk. Using locally food to make a complementary food of breast milk like fish have many advantages, such as high protein and easy to digest, cheaper, easy to get and can be used for educating of under two years children to know variety of food. If the children are knowing of many variety of food so hopefully they can like of variety of food around of them. The aim of this research is analyzing protein ingredient in the tilapia fish flour.

METHODS

Tilapia fish that will be used as a raw material for making complementary food of breast milk is came from Tasikmalaya. Kjeldahl method is used in this research to identify protein ingredient of tilapia fish flour. This research is done in BPTBA LIPI laboratory in Gunung Kidul Yogyakarta. The methods of making tilapia fish flour used steaming technique. Ingredient of Tilapia fish flour were 1) Tilapia fish, 2) green bean and 3) Egg soybean fermented. Graph was used to describe of the research result. Presentation of nutrition content in the tilapia fish flour was also using frequency distribution table. Protein that was resulted by this process will be compared with Indonesian list of food composition (DKBM).

RESULT AND DISCUSSION

The complementary food of breast milk is a solid food that is given to accompany breastfeeding period for the children who have aged 6 months until two years old. Giving additional food to recovery of undernutrition is a program that is done by government. Tilapia fish is called a perishable food. Therefore, sending process of tilapia fish should be done by considering of the fish freshness.

Sending process fish to BPTBA LIPI laboratory was using live tilapia fish so was expected when the fish arrived in BPTBA was still in the freshness condition. Tilapia fish was brought from Tasikmalaya to Gunung Kidul, Yogyakarta by using of plastic bags that was filled by water and oxygen. Every single plastic bag was used to fill approximately 3-5 kg of fish. Car was used to brought fish with consideration more practical and faster than using train. The journey of sending process fish need more than 11 hours. The car departed from Tasikmalaya at 9 pm and arrived at Gunung Kidul at 8 am. Most of the fish when arrived at gunung kidul was still alive and the fish was moved to the cleaning pond as soon as possible.

This research used tilapia fish that had weight 200gr. Tilapia fish has a faster growth than the other fish, especially the fish that alive in shallow water. It is caused by the fastest of water plant growth, so tilapia fish can get a lot of feed. After the weight gain of tilapia fish is reaching a 200 gr then the growth rate will become slowly. In this size, the tilapia fish will be harvested by most of the fish farmer. This size is also a appropriate size to consume.

The step of making tilapia fish flour were 1) throw out the fish squama and viscera, 2) cleaning fish with cleaned water to release the dirt, mucus and blood, 3) draining the fish to reduce of the water contents, 4) steamed the fish, 5) separating meat and fish bone, 6) drying the fish with high temperature using oven, 7) smoothing the fish to make flour and 8) sift the fish flour. The next step was analyzing protein contents in the fish flour and the other ingredients (green bean and egg soybean fermented).

Table result of protein analysis

Flour ingredients	Protein*
Tilapia fish	77.7
Green bean	31.8
Egg soybean fermented	52.4

*Per 100 gr

Protein analysis using kjeldahl method showed that in the 100 gr of tilapia flour was resulted protein amount 77,7. Protein that was resulted from green bean was 31,8 and from egg soybean fermented was 52,4. The characters of Tilapia fish are 1) a freshwater fish, has a flat body shape, 3) grey, brown and black coloured, 4) easy to adaptation in every place (can adaptation in unstandardized environment). Tilapia fish is the most tolerant fish toward salinity so they still alive in brackish water. They also can live in a high ammonia water (more than standart), or in the water with limited oxygen. Tilapia fish is a high quality fish because contain a high non allergenic protein, has a complete protein, and contain all of essential amino acids that are needed by human body. Amino acids is needed to increase number of protein. Beside that, tilapia fish rich of omega 3 that is important to children growth and optimizing development of children brain.

Green bean is a cultivated crop that is widely known in tropical area. This plant is including of legumes family (*Fabaceae*) which has many advantages. One of the advantage is content of high of vegetable protein. In Indonesia, green bean is the 3rd most important of legumes if compare with soybean and peanut. Green bean seed is smaller than the other seed of legumes family. There are 3 part in the green bean seed, it are seed shell (10%), kotiledon (88%), and core seed (2%). Seed shell is containing many minerals such as Phosphorus (P), Calcium (Ca), and Ferrum (Fe). Kotiledon has a lot of starchs and fiber, while a seed core is protein and fat sources.

Soybean fermented is a traditional food fermented from Indonesia that it is mainly made by soybean. Soybean fermented is a processed product that is made by soybean with *Rhizopus oligosporus*. This food is renowned in Indonesia. More than a half people in Indonesia have been consumed soybean fermented and tempe is the most often eaten side dish, especially by lower middle economic family. Beside that, soybean fermented have a many superiority, such as 1) easy to produce, 2) the price is affordable, 3) always available in the market and 4) easy to cook.

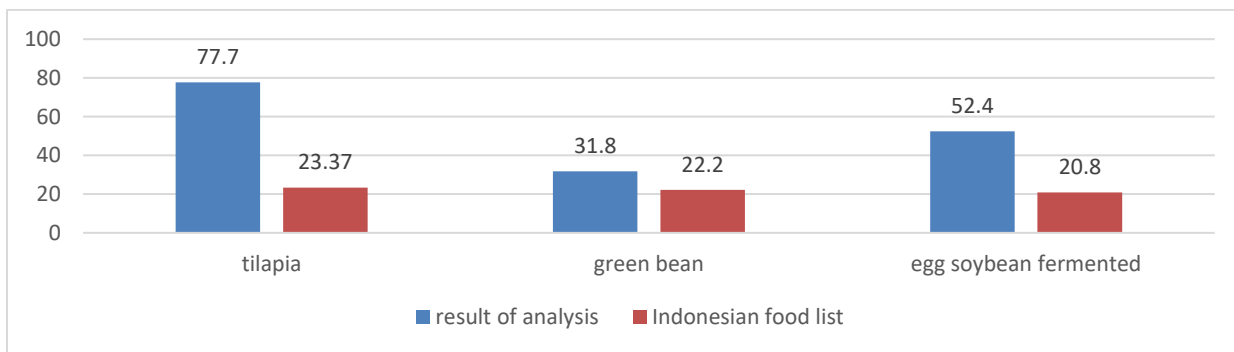

Graph. The comparison of protein that is resulted from kjeldahl analyzis and Indonesian food list (2007)

Protein content in the three ingredient that is used for process making tilapia fish flour was significantly higher than protein content in Indonesian food list. Tilapia fish flour had protein content 7,7. It is higher than protein content of tilapia fish in Indonesian food list (22,37). It was also occurring for protein contained in the green bean and egg soybean fermented.

REKOMENDATION

Process to made tilapia fish flour was done using tilapia fish and the other ingredient. The ingredient were green bean and egg soybean fermented. All of protein in the ingredient of tilapia fish flour is higher than Indonesian food list.

Thank you

We would like to thank you to DRPM Ministry of Research and Higher Education, also to LPPM-PMP UNSIL for the contribution in this research. Also to BPTBA that have been supporting this research since the beginning.

DAFTAR PUSTAKA

BAPPENAS, 2011, *RANPG - Rencana Aksi Nasional Pangan dan Gizi 2011-2015*, BAPPENAS, Jakarta

Diah M. Utari, dkk, 2010. *Pengaruh Pengolahan Kedelai Menjadi Tempe Dan Pemasakan Tempe Terhadap Kadar Isoflavon (Effects Of Soybean Processing Becoming Tempeh And The Cooking Of Tempeh On Isoflavones Level)* , jurnal pangan dan gizi, Vol 33(2): 148-153

Kemenkes RI, 2010, *Pedoman Kader Seri Kesehatan Anak*, Kemenkes RI, Jakarta

Kemenkes. 2014. *Hasil Riskesdas 2013*. Kemenkes RI

Lilik Hidayanti & Sri Maywati. 2014. *Ketahanan Pangan (Food Security) Dan Status Gizi Balita Keluarga Miskin Di Kecamatan Sukarame Kabupaten Tasikmalaya*. Laporan Penelitian Dosen Madya Universitas Siliwangi

Lilik Hidayanti & Sri Maywati. 2015. *Ketahanan Pangan Keluarga Miskin yang Memiliki Balita Gizi Kurang di Wilayah Pedesaan dan Perkotaan*. Laporan Penelitian Dosen Pemula

Meyliana, dkk. 2013. *Potensi Budidaya Ikan Mujair: Studi Kasus di Kecamatan Leuwisari Tasikmalaya*, Laporan Penelitian Universitas Maranantha

Puskesmas Sukarame, 2014, *Laporan Tahunan Puskesmas Sukarame*, Puskesmas Sukarame

Sri Maywati & Lilik Hidayanti. 2014. *Upaya Meningkatkan Ketahanan Pangan (Food Security) Keluarga Yang Memiliki Balita Kekurangan Gizi Dengan Promosi Konsumsi Makanan Beragam Berbasis Sumber Daya Lokal Melalui Konseling Gizi*. Laporan Penelitian Dosen Pemula

Rahman Suleman M. Kes "Identify The Number Of Medical Recorder Along With Educational Qualification At Non- Government Hospital In Gorontalo City"

ABSTRACT



Back Ground: As a health service facility, the Hospital have to provide quality health service and able to assure the patient. The medical record is one of the most important unit in the Hospital, which plays an important role in improving the quality of health services. **The aim:** of this research is to identify the number of medical recorder with their education qualification at non-Government Hospital in Gorontalo City. **Method:** used in this research is obesrvasi secondary data. Data on the number of officers and the last education of medical records officers obtained through observation of data available in the Hospital. **Result:** the research obtained shows that the number of medical recorder in Multazam Hospital is 3 people, 11 people of Mother Bunda Hospital, and Islamic Hospital is 3 people. For medical recorder education qualification at RS. Multazam S1 Public Health amounted to 2 people, and SPK.C amounted to 1 person. Education qualification of medical recorder officer at RS Bunda consists of 5 students, 2 Vocational High School, Bachelor's education teacher amounted to 2 persons, Bachelor of Law amounted 1 person, 1 Bachelor of economic amounted to 1 person. For Multazam Hospital, Nursing scholars amounted to 1 person, Bachelor of Public Health amounted to 1 person, and Senior High School 1 person.

WORKING STATION MODEL BASED ON MATHEMATIC MODEL OF ANTROPOMETRY FOR EMBROIDERY WORKERS

Asep Suryana Abdurrahmat¹⁾, Rian Arie Gustaman¹⁾ and Yuldan Faturahman¹⁾

¹⁾ Faculty of Health Science, Siliwangi University

ABSTRACT

Oftenly the embroidery craftsmen do their work by ignoring the unbalance of their anthropometric size with the size of the tables and chairs used. This condition cause unergonomically sitting position when they are working that will triggers variety of subjective complaints of craftsmen, especially in muscle and joint.

Conducted development research by using 4D model (devine, design, develop and disseminate) based on anthropometry size to build chair and table as more ergonomic work station for embroidery craftsmen. The first three stages are done by analyzing the compatibility of anthropometry of the body with the size of work station used by mathematical approach and laboratory scale test. The acceptance level of craftsmen on the prototype of work station model measure by TAM model (technology accepted model) that conducted on a public scale.

The result of this research is the establishment of more ergonomic prototype of work station model for embroidery craftsmen and based on the result of public scale exam of 180 embroidered craftsmen showed that 63% of respondents stated less subjective complaints of muscle and joint disorders at the shoulders, 71% Subjective complaints of muscle and joint disorders in the upper arm and respondents stated reduced subjective complaints of muscle and joint disorders in the 56% after using a new work station model. However, it is still necessary to make improvements to the prototype of the work station model to be more ergonomic and to suppress the emergence of subjective complaints of muscle disorders and joints of embroidery craftsmen.

Keyword: prototype, work station, ergonomics, craftsman embroidery

INTRODUCTION

Embroidery Craft is one of superior product from Tasikmalaya which is famous and has a wide market share. Embroidery craft which mostly in the form of home industry absorb quite a lot of manpower especially among productive age. Based on data from the Department of Industry in 2013, the center of Tasikmalaya embroidery industry spread in 24 villages from 12 sub-districts. This industry is able to absorb the workforce of 31,765 people with 17,000 details coming from Tasikmalaya City and the rest coming from Tasikmalaya Regency. The workers are spread over 2,708 business units.

Kawalu sub-district is listed as the region that has the most entrepreneur of handicraft business, namely 87.7 percent of total embroidery crafters in Tasik. The region that has the largest business unit in Kecamatan Kawalu is Tegalsari Village which produces high quality embroidery such as Turatex, Purnama, Ciwulan, Haryati and Flower Tanjung. Its total production reaches 7.2 Million pieces per year with its production value has reached the figure above Rp 500 billion (pikiran-rakyat.com2013)

The working station currently used by most craftsmen is a sewing machine placed on a flat table with a non-ergonomic wooden bench. The wooden bench in question is a separate part

of the sewing machine table and is not equipped with a backrest or armrest and has a fairly hard seat. This state of work station forces craftsmen to form a variety of working angles that do not fit comfortably for a sitting position.

The design of desks and chairs and other work stations should be tailored to the anthropometry size of the user's body. According to Rosewood (2003), anthropometry is the measurement of body dimensions or other physical body characteristics that are relevant to the design of something that people wear. On the other hand, Baumgartner (2003) explains that an ergonomic work station will encourage users to adapt, resulting in the emergence of erroneous working positions. The position will be done continuously and become a bad habit (bad habit) of someone during activity.

The attitude of craftsmen and the work station model that is uncomfortable and safe for the body often creates various problems for the body. Problems experienced by the craftsmen related to the physiological adaptation of the body that has reached the maximum limit so that there is a change of work system of the body forced to adjust the conditions of work station and work organization. If this situation continues, it will appear various physical complaints, especially the emergence of pain in muscles and joints.

RESEARCH METHODS

Research Activity

This research activity will generally be carried out in 3 years. In the first year is an activity of collecting data and information either from embroidery company owner, or from embroidery worker as material of design of work station prototype or model which more ergonomic. In the second year is the improvement of work station model through laboratory experiments and the implementation of work station model in the embroidery company at the district of Kawalu Tasikmalaya City. In the third year is acceptance analysis by using model modified Technology Acceptance Model (TAM) in order to be used to know the level of user acceptance of the model of work station created.

Methods

The type of research is development research with 4D model (Devine, Design, Depelov and Disseminate). The research stages are as follows:

- a. The devine stage is done through direct observation of the job execution process to obtain data about the anthropometry size of the craftsman body, the size of the work station used and the subjective complaints of muscle and joint disorders experienced. In this process is done with approach method 5W + 1H
- b. Design stage is done by changing the various body sizes and the size of the work station into several angle sizes when working position. Further analyzed the angle relationship of the working position with the appearance of subjective complaints of muscle and joint disorders of the craftsmen. From the analysis result, it is made adjustment of design of work station model in the form of sketch of work station model able to form ideal working position angle.
- c. Depelov stage is done by building a work station for embroidery craftsmen based on sketches of designs that have been made
- d. The disseminate stage is done through TAM (Technology Accepted Model) approach to measure public acceptance of technological innovation. This stage is done through 2 ways of testing are:

- 1) Laboratory scale test to analyze work station model based on ergonomic principles involving 15 craftsmen as comparison. The results of this stage allow for a design change from the work station that has been created.
- 2) A public-scale test involving a larger number of craftsmen to measure the level of public acceptability based on the safety level and the artist's sense of comfort associated with the subjective complaints of muscle and joint disorders they experience.

RESULTS

The Devine Stage

Result of analysis of validity and reliability of indicator to latent variable of antropometry measure by using CFA show that there are 10 of 12 body size that can be used as parameter to represent anthropometry variable of craftsman shown in table 4.1

Table 4.1 Results of Confirmatory Analysis of Body Size Parameters as Anthropometric Indicators

No	Body Size	Rho Value	<i>p</i> Value
1.	Standing height	0,113	0,320
2.	Long range	0,721	0,000
3.	Shoulder height	0,174	0,298
4.	Shoulder wide	0,492	0,010
5.	Buttock wide	0,773	0,000
6.	Sitting height	0,756	0,000
7.	Sitting elbow heingt	0,751	0,000
8.	Sitting buttock height	0,862	0,000
9.	Sitting knee height	0,771	0,000
10.	Sitting upper leg length	0,458	0,008
11.	Sitting lower leg length	0,442	0,007
12.	Range of eyes to object	0,762	0,000

The result of the analysis on the measurement of the work station both table and chair using CFA shows that some parameters that become indicator for ergonomics of work station can be seen in table 5.2

Table 5.2 Results of Confirmatory Analysis of Table-Chair Parameter Size as an Ergonomic Indicator of Work Station

No	Work Station Size	Rho Value	<i>p</i> Value
1.	Table height	0,713	0,000
2.	Table wide	0,274	0,041
3.	Table length	0,892	0,000
4.	Foot support height	0,473	0,003
5.	Chair heighth	0,872	0,000
6.	Chair wide	0,673	0,000
7.	Seat heighth	0,776	0,000
8.	Seat mat	0,795	0,000

Both measurements are then converted into angles formed by the body of the craftsmen while their work. The angle becomes an indicator of antropometrical balance of the craftsmen

body with the ergonomics of the table and chair as the working station their used. Table 5.3 shows the magnitude of the angle formed when the embroidery craftsman works.

Table 5.3 Results of Confirmatory Analysis of the Corner of the Embroidery Artist When Working

No	Body Angel Parameter	Angel Size (°)	Rho Value	P Value
1.	Angles formed between the toes with the soles of the feet	100 – 105	0,172	0,253
2.	Angles formed between the sole of the foot with the lower leg	90 – 110	0,092	0,200
3.	Angle formed between the lower leg with the upper leg	90 – 110	0,080	0,187
4.	Angles formed between the upper legs with the buttocks	60 – 80	0,758	0,000
5.	Angles formed between the back with the neck	155 – 180	0,443	0,048
6.	Angles formed between the neck with the head	155 – 180	0,401	0,037
7.	Angle that is formed upper arm with shoulder	25 – 90	0,728	0,000
8.	Angles formed between the upper arm and the forearm	110 – 160	0,625	0,000
9.	Angle formed between the forearm with the palm of the hand	165 – 180	0,023	0,183
10.	Angles formed between the palms of the hands with the fingers of the hand	165 – 180	0,018	0,200

Furthermore the results of confirmatory analysis of the appearance of subjective complaints of muscle and joint disorders in the embroidery craftsmen can be seen in table 5.4.

Table 5.4 Results of Subjective Complaints Confirmation Complaints of Muscle and Joint Disorders

No	Work Station Size	Rho Value	P Value
1.	Complaints Pain in the Head	0,171	0,200
2.	Complaints Pain in the Neck	0,475	0,041
3.	Complaints Pain in Shoulders	0,595	0,016
4.	Complaints Pain in the armpits	0,683	0,000
5.	Complaints Pain in the Arm Section	0,422	0,159
6.	Complaints Pain in the Wrist	0,476	0,162
7.	Complaints Pain in the Hinges of Hands	0,092	0,428
8.	Complaints Pain in the Back	0,485	0,026
9.	Complaints Pain in the Waist	0,682	0,000
10.	Complaints Pain in the buttocks	0,667	0,000
11.	Complaints Pain in Knee Section	0,418	0,148
12.	Complaints Pain in the ankle	0,182	0,200
13.	Complaints Pain in the Toes of the Feet	0,081	0,420

Table 5.4 shows that significant subjective complaints of muscle and joint disorders occur only in the body of the neck, shoulders, armpits, back, waist and buttocks. The priority of handling based on the strength of the relationship. The body of embroidery craftsmen on the armpit, waist and buttocks are the most risk parts of the body affected muscle and joint disorders.

Further data processing using path analysis to antropometry data of craftsmen body, table and chair size (work station) and subjective complaints of muscle and joint disorders indicate that there are several anthropometry parameters of craftsmen body and work station size that can be used as indicator of cause the appearance of subjective complaints of muscle and joint disorders in the embroidery craftsmen.

Table 5.5 Result of Path Analysis of Inter-Latent Liaison Relationships

No	Model of Relationships	Rho Value	p Value
1.	Antropometric Size \longrightarrow Subjective Complaints	0,628	0,000
2.	Ergonomic Work Station \longrightarrow Subjective Complaints	0,841	0,000

The result of the analysis can then be formulated the relationship between antropometry size of craftsmen and an ergonomic work station with the emergence of subjective complaints as muscle and joint disorders in embroidery craftsmen by mathematically formulation :

$$SC = 0.68 AS + 0.84 EWS$$

Where SC is Subjective Complaint, AS is Anthropometric Size and EWS is Ergonomic Work Station.

The Design Stage

The next stage is to determine the design of table and chair that are recommended to be used as work station by embroidery craftsmen. Work stasion is made based on the results of the analysis in the previous stage by considering the amount of angles that become indicators of the ergonomic equilibrium of working station.

The design of the table and chair should be adjusted to the antropometric size of the craftsmen who have different quantities. Therefore it is necessary to made the flexibility of chair height and the flexibility of distance of the table with the chair to occur an ergonomic balance between the craftsmen with their work station and the emergence of comfort when their used.

Table and chair which made as a work station is tied each other or not separate as common embroidery work station. However, there are regulators to change the position of the chair forward and back so that the worker can easily adjust the distance between the table with the seat as comfortable as possible which implies the formation of safe angles on the buttocks, waist and knees.

In addition, the height of chairs can also be up-down so that it can adjust to the height of each worker sitting. This also implies the formation of an ideal angle on the neck, back, knees, ankles, armpits and shoulders. Created also a seat chair that can be adjusted angle so that the craftsmen can lean while working

The last thing to take into consideration is the foam laminated by the fabric on the seat mat and the chair back so that the worker can sit comfortably. The design of work stations made from metal material so it is durable and easily formed

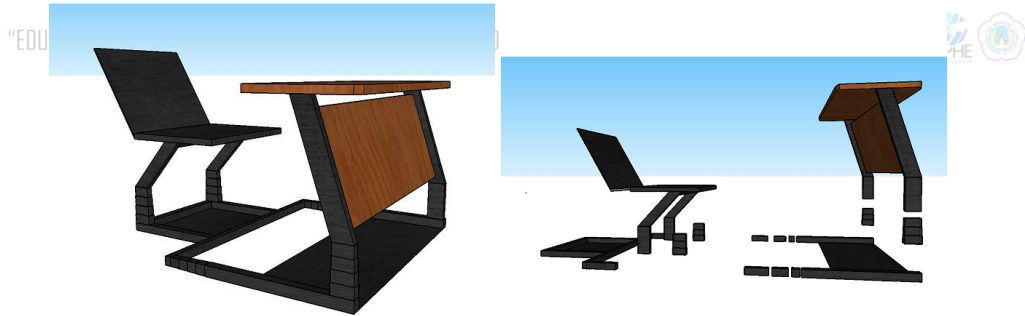

Figure 5.1
The Design of Work Station For Embroidery Craftsmen

The design is subsequently converted into a technical or engineering sketch to facilitate the creation of a more ergonomic work station

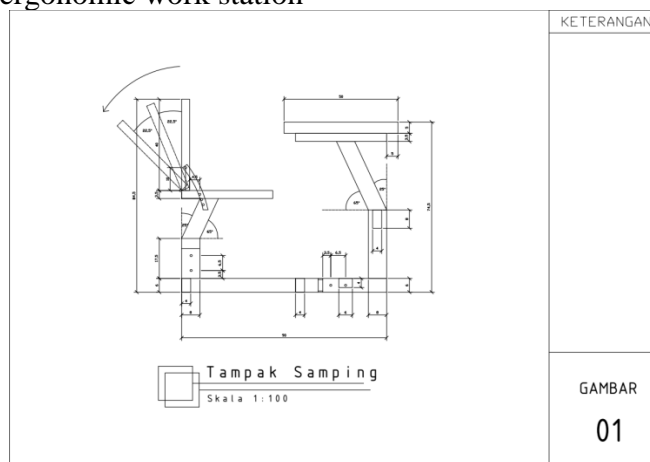
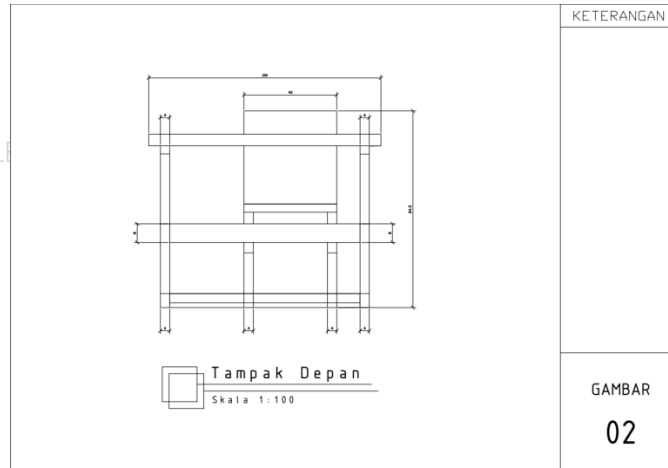
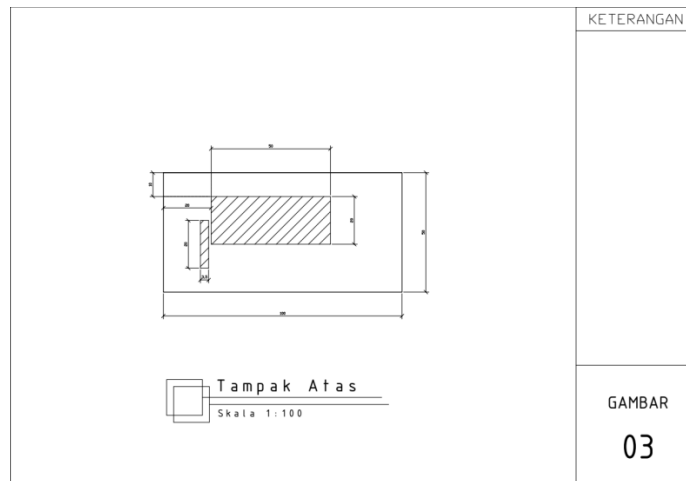

Figure 5.2
Engineering Sketch, Side view of Working Station For Embroidery Craftsman



Gambar 5.3
Engineering Sketch, Front View Working Station For Embroidery Craftsman



Gambar 5.4
Sketch Technique, Top View Work Station For Embroidery Craftsman

The Depelov Stage

Stage of development of work station done after reviewing result of mathematical analysis which subsequently poured in design of work station. A working station prototype is made available to each craftsman with different anthropometric sizes. Forms of work station can be described into several parts, among others:

1. The basic frame of metal



Figure 5.5
Structure of Frame Embroidery Working Stations

2. Table mat made of melamine polywood material



Public Health Department - Sport And Health Faculty - Gorontalo State University
Figure 5.6
Embroidery Working Table Matter

3. Seats for backrest and pads made of fabric and foam.



Figure 5.7

Seat Backrest and Pad of Embroidery Working Stations

Thus the complete shape of the working station created can be seen in Figure 5.6



Figure 5.8

Prototype Working Stations Embroidery

The Disseminate Stage

It will be done at second and third year

DISCUSSION RESEARCH

Results of research shows that the daily work position of the craftsmen is form an angle position that tends not to be ergonomic. This is due to an imbalance between the size of the worker's anthropometry and the size of the working station used. The angle that is formed tend to be taper or less than 90°. The angles that should be concerning when their in sitting position are : (1) the angle formed between the upper legs with the buttocks, (2) the angle formed by the upper arm with the shoulder and (3) the angle formed between the upper arm and the forearm. This is in line with the opinion of Taylor and Bogin in Bhattacharya and Glothin (2001) explains that the angle formed in the sitting position is strongly influenced by the size of the length of the legs both up and down with seat height. In addition to the upper body of the angle that is formed when sitting depends on the length of the body with the height of the work table.

Taper angle will make the muscle clamped blood vessels that exist around it so that the lumen of blood vessels become narrower and blood flow becomes slower. This condition makes the supply of nutrients and oxygen decreased. The muscles that are actively working will change the energy system used slowly from aerobic to aerobic. Murray (2003) explains that it can happen when the muscle lacks oxygen supply and the energy source used glucosa as an ATP provider. This simple sugar molecule will be transformed through a series of enzymatic chemical reactions in the muscle cytoplasm become to pyruvic acid. Furthermore the pyruvic acid molecule will be altered according to the oxygen condition of the muscle. If the level of oxygen deprivation in the muscle is not too high then pyruvate can be converted back into glucose and glycogen, but if the condition of oxygen deprivation in the muscle lasts long then the pyruvic acid will be converted into lactic acid. Therefore, continuous muscle contraction over a long period of time can lead to increased production of lactic acid that appears as a by-product of anaerobic muscle energy usage. Produced lactic acid will enter and flow inside the blood vessels.

Mc Ardle (2002) explains that when blood lactate acid concentration increases with continuous muscle contraction over long periods then blood viscosity will increase and blood flow becomes slower, especially in joints. Lactic acid that has a high enough density is difficult to escape in the joints, resulting in accumulation of lactic acid in the joints that will cause pain. This is in line with the results of research showing that the emergence of subjective complaints of muscle and joint disorders experienced by the craftsmen more felt in the armpit, waist and buttocks that are part of the body with a pointed angle as they work.

Therefore It is appropriate to construct a working model model for embroidery craftsmen aim to improving these pointed angles by modifying their work station models which considering an ergonomic equilibrium.

CONCLUSIONS AND SUGGESTION

Conclusions

1. Subjective complaints of muscle and joint disorders result from an imbalance between the anthropometric size of the embroidery craftmen body and the size of the work station that they use. The contribution of anthropometric size of craftsmen and the size of work station to the occurrence of subjective complaints of muscle and joint disorders respectively by 68% and 84%.

2. It should be need to make a model of work station for embroidery craftsmen by considering the size of their anthropometry and the size of their work station that form a more gentle seating angle, especially on the shoulders, armpits, waist and buttocks.

Suggestion

It should be needs to be socialized to embroidery craftsmen and a kind of workers that work with similar work station and similar work position to pay more attention to the balance of their body size with the size of their work station such as the size of chairs and tables used.

REFERENCES

- Andersen Torben M., 2007 , *The Nordic Models*, Helsinki : Yliopistopaino.
- Ganong William F., 2002, *Buku Ajar Fisiologi Kedokteran*, Jakarta : EGC
- Katch I. Frank, 2003, *Human Physiology, edition^{6th}*, Toronto : Scott Freshman Publishing.
- Kromer, Kroemer, Kroemer-Elbert. 2001. *Ergonomics: How to Design for Ease and Efficiency*. United States of America: Prentice Hall.
- Mc Ardle William D., 2002, *Exercise Physiology*, Baltimore : William & Wilkins Company.
- Reese Charles D., 2004, *Office Building Safety and Health*, New York : CRC Press
- Rosewood Rupert S., 2003, *Ergonomic Work Station In Industrial*, Nebraska : William & Wilkins Co.
- Santoso Gempur, 2004, *Ergonomi Manusia, Perlatan dan Lingkungan*, Jakarta : Prestasi pustaka Publisher.
- Steele Robert G. D., 2002, *Prinsip dan Prrosedur Statistika*, Jakarta : Gramedia Pustaka Utama
- Sujarwadi Sugeng, 2006, *Penatalaksanaan Organisasi Kerja*, Bandung : Pustaka Angkasa.
- Sullivan Margareth, T., 2002, *Determinat Work Organization*, California : Burgerr publishing Co.
-, 2008, *Office Ergonomic Handbook 5th edition*, Ontario : Occupational Health Clinics for Ontario Worker Incoorporation.

ABSTRACT

SEXUAL BEHAVIOR DIFFERENCES IN ADOLESCENT RISK STUDENTS WHO SCHOOL IN URBAN AND RURAL SCHOOLS GORONTALO

"EDUCATIONAL CHALLENGES AND STRATEGIES OF HIGHER EDUCATION IN HEALTH ACHIEVEMENT OF SDGS 2030"



Dewi Kartika

ummidhewy_84@yahoo.co.id

0811 43 91 84

Background: Based on data from the WHO in 1993, is closely linked to the performance of young people in school, in 1990 as many as 60 out of 1,000 girls aged between 13 and 19 years in the United States had given birth until the year 2000 this number had dropped to 50 out of 1,000 teenage girls every year 900,000 girls teens in the United States faced with a very difficult choice to abort her baby

methods: This type of research that is in use is Observasionalanalitik komparataif research with cross sectional study, by means of observational

result: From the results of research using the chi-square test on the table 4:17 then obtained 37.425 X2 count because X2 count > X2 tables 3.84 and p-value (0.000 < a.0,05) This means that Ho was rejected and Ha accepted, data analysis using the chi-square test on the table 4:18 then obtained 10.570 X2 count because X2 count > X2 tables 3.84 and p-value (0.002 < a.0,05) this means that Ho was rejected and Ha accepted. Independent t test results in the test sample found mean value of p = 0.000 Ha Ho accepted rejected

Suggestion : Was expected to teens, especially high school students and high school I City I Tibawa Gorontalo can improve understanding of reproductive health by means of active reading books on reproductive health and do not be shy to ask about health problems.

Keywords : Exposurepornography, Attention parents, Environment, puberty, Friends, risk sexual behavior

PRELIMINARY

Adolescents in psychological science introduced by other terms, such as *puberteit*, *adolescence*, and *youth*. In the discussion of Indonesia is also often associated puberty or teenagers. during the remaja (ages 12 to 21 years), there are several phases, one of which is the phase of early adolescents (ages 12 to 15 years), which also included a phase of puberty which is a phase that is short and sometimes a problem for teenagers in face it (Angriyani and Trisnawati, 2011).

A survey carried out by the *Youth Risk Behavior Survey* (YRBS) nationally in the United States in 2006 found that 47.8% of students in grades 9-12 have premarital sex, 35% of high school students have been sexually active (Banun and Setyorogo, 2013).

Premarital sexual behavior among teenagers raises many problems. In terms of health, such behavior can cause adolescents contracting HIV / AIDS and other sexually transmitted diseases (STDs). Based on data from the Ministry of Health of the Republic of Indonesia issued in June 2013, informed that the number of HIV / AIDS positive patients in Indonesia amounted to 103,759 people, with the highest risk factor of transmission through heterosexual relationship of 59.8%. As for the distribution of HIV positive cases in the group of adolescents aged 20-24 years is 14.0% or 14 527 adolescents diagnosed HIV positive (Hidayat et al, 2012).

Based on data from the Indonesian Demographic Health Survey 2012 of the Youth Reproduction Health (SDKI 2012 KRR) component, nationally there is an increase in the number of adolescents who have had premarital sexual intercourse compared to data from the Indonesian Youth Reproductive Health Survey (SKRRI) 2007. Survey results of the 2012 KRR showed that approximately 9.3% or about 3.7 million adolescents declared having premarital sexual intercourse, while the results of SKRRI 2007 only about 7% or about 3 million adolescents. Thus during the period of 2007 to 2012 increased cases of teenagers who had sexual intercourse was 2.3% (Hidayat et al, 2012).

The survey results were done generally done by the Child Protection Agency (LPA) d In the 12 provinces of Indonesia in 2007, especially in the big cities show quite astonishing results where 93.7% of children and secondary school has done petting, (paste tool sex), kissing, and oral sex (oral sex), 62.7% of junior high school children are not virgins 21.2% high school girl has had an abortion and skitar 97% students of junior and S MA often watch porn (Haryanto, 2013) .

Based on secondary data in getting the Commission Pena ng g u Langan A IDS (KPA) of Gorontalo province in 20 12 -201 5 suffering from HIV / AIDS and of 2012-201 5 suffering from HIV / AIDS totaled 38 people with HIV / AIDS. (KPA, Gorontalo Province, 2015). So researchers interested in conducting research with the title Differences risky sexual behavior in young school students in urban and rural schools in Gorontalo 2015.

METHOD

This type of research is *observational* research comparative *analytic* with *cross sectional study*, namely a study design that is studying the dynamics of independent variables and the dependent variables simultaneously. while the dependent variable was sexual risk behavior in adolescents and variabl e independent student ie exposure pornog Rafi, parents' attention, an environmental n, friends, and the age of puberty.

Research conducted at the two schools are in school SMA Negeri I Gorontalo and in SMA I Tibawa Y ear 2015. The population in this study is the population in this research is all class XI students who study in SMA I Gorontalo and all class XI students who study in SMA I Tibawa, with the number 689 siswa.teknik sampling used was *stratified random sampling* where the SMA Negeri 1 Kota Gorontalo many as 140 students and in SMA 1 Tibawa as many as 106 students.

Data were analyzed using *Chi Square* and *independent t* test to see whether there is any difference in risky sexual behavior in adolescents students of urban schools and in pedesaan.Variabel independent and dependent variable is said to have a difference if the value of P = (<a.0,05).

RESEARCH RESULT

The results of the analysis of *Chi Square* and *Independent T* test showed that exposure to pornography teenage students in obtaining X^2 count 37.425 because X^2 count > X^2 tables 3.84 and the p-value (0.000 <a.0,05) This means that Ho is rejected and Ha accepted. Means there is a relationship between exposure to pornography with sexual risk behavior In high school I Gorontalo City 201 Year 5.

Table 1 Analysis Against Pornography Exposure Risk Sexual Behavior In Teens Students in Urban and Rural Areas In high school one of Gorontalo in 2015.

Pornographic Exposure	Sex Behavior at Risk				Percentage
	Risk		No Risks		
	N	%	N	%	
High	31	35.2	57	64.8	88 (100)
Low	46	88.5	6	11.5	52 (100)
Total	77	55	63	45	140 (100)

$X^2 = 37.425, P \text{ value} = 0.000$

The results of the analysis of *Chi Square* and *Independent T* test showed that the attention of the parents in obtaining X^2 count 10.570 because X^2 count > X^2 tables 3.84 and the p-value (0.002 < 0.05), this means that H_0 is rejected and H_a accepted. Means there is a relationship between parents' attention with risky sexual behavior in high school I Gorontalo City 201 Year 5.

Table 2 Analysis of Attention Parents Against Risk Sexual Behavior In Teens In Urban and Rural Students In High School 1 Gorontalo City in 2015.

Parents attention	Sex Behavior at Risk				Percentage
	Risk		No Risks		
	N	%	N	%	
Less	23	38.9	36	61.1	59 (100)
Enough	54	66.7	27	33.3	81 (100)
Total	77	55	63	45	140 (100)

$X^2 = 10.570$, P value = 0.002

The results of the analysis of *Chi Square* and *Independent T* test showed that the environment is obtained X^2 count 0,535 because X^2 count < X^2 tables 3.84 and a p-value (0.575 > 0.05), this means that H_0 is accepted and H_a rejected. Indicates no relationship between the environment and risky sexual behavior in high school I Gorontalo City 201 Year 5.

Table 3 Environmental Analysis Of Risk Sexual Behavior In Teens Students in Urban and Rural Areas In high school one of Gorontalo in 2015.

Environment	Sex Behavior at Risk				Percentage
	Risk		No Risks		
	N	%	N	%	
Bad	38	52.1	35	47.9	73 (100)
Good	39	58.2	28	41.8	67 (100)
Total	77	55	63	45	140 (100)

$X^2 = 0.535$, P value = 0.575

The results of the analysis of *Chi Square* and *independent t* test showed that puberty was obtained X^2 count 1,966 because X^2 count < X^2 tables 3.84 and a p-value (0.218 > 0.05), this means that H_0 is accepted and H_a rejected. Means there is no relationship between puberty with risky sexual behavior in high school I Gorontalo City 201 Year 5.

Table 4 Analysis of puberty Against Risky Sexual Behavior In Teens Students in Urban and Rural Areas In SMA 1 Gorontalo 2015

Puberitas	Sex Behavior at Risk				Percentage
	Risk		No Risks		
	N	%	N	%	
Anomalous	30	48.4	32	51.6	62 (100)
Normal	47	60.2	31	39.8	78 (100)
Total	77	55	63	45	140 (100)

$X^2 = 1.966$, P value = 0.218

The results of the analysis of *Chi Square* and *Independent T* test showed that the friend obtained X^2 count 1,326 because X^2 count < X^2 tables 3.84 and a p-value (0.328 > 0.05), this means that H_0 is accepted and H_a rejected. Means there is no relationship between friends with risky sexual behavior in high school I Gorontalo City 201 Year 5.

Table 5 Analysis of puberty Against Risky Sexual Behavior In Teens Students in Urban and Rural Areas In SMA 1 Gorontalo 2015

Friend	Sex Behavior at Risk				Percentage
	Risk		No Risks		
	N	%	N	%	
Bad	44	48.4	42	51.6	86 (100)
Good	33	60.2	21	39.8	54 (100)
Total	77	55	63	45	140 (100)

$X^2 = 1.326, P \text{ value} = 0.328$

T-test analysis results of *the Independent t-test* p value = 0.0000, meaning at alpha 5% there are significant differences between urban schools and rural schools

Table 6 Analysis of Differences in Risk Behavior Toward Risk Sexual Behavior In Teens Students in Urban and Rural Areas in Urban and Rural High School.

Sexual At Risk	Mean	SD	SE	P Value	N
Urban	69,13	11,470	2.961	0,000	15
Rural	38.60	10,550	4,718		5

DISCUSSION

Adolescence is the stage in which a person has experienced an important period in his life that is the transition from childhood to adulthood. sexual maturity in adolescence leads to the emergence of sexual interest and a high desire for sexuality. The low knowledge of reproductive and sexual health resulted in the inappropriate interpretation, perception and attitude in preventing premarital sexual behavior (Dewi Setyowati, 2012).

Based on the results of the study obtained data that the age of the largest respondents is 19 years and the smallest age is 16 years. The age limit is appropriate respondent in the survey respondents make keterpaparan pornography, parental, environment, the age of puberty, friend.

As seen in the previous chapter the purpose of this study focuses on adolescents are done in order to get accurate data as presented in the shows the needs of teenagers, especially students.

1. Exposure to pornography

Pornographic exposure is very influential on sex in adolescents because, Almost all countries, including the liberal United States even though, also prohibit the spread of pornography. pornography in general is writing, drawing, or audio-visual products, which can stimulate sexual desire, pornographic material presented in certain media that can be shown to arouse sexual desire khalak or mengeplaitasi sex. teenagers are now a lot of who see the action of pornography, so they want to mencha these things

pornography is deemed to undermine reproduction and reproductive mechanisms as a recreational activity that has no pure noble divine in promoting collective moral degradation, resulting in corrupt implications for established social institutions such as family, religious institutions, education and so on, the corrupt nature of pornography is dealing with the values assumed in this collective grasp causing pornography categorized as an unproductive deviation to the dynamics of collective values. Thus, behavior related to pornography needs to be corrected by social institutions.

Based on the results of the study of pornography exposure Andrew (2001) in black girls 14-18 years of age report those exposed to pornographic video films have more bnyak boyfriend, more frequent sexual intercourse, electronic and print media, became the largest contributor to the breakdown of teenagers. Especially television because its presence almost full time (24 hours) in front of us. You can imagine if teenagers every day work can only be imagined if teenagers every

day work just watching television then the behavior and the principle of life (way of life) is a cheat from what he saw on television.

Based on Table 4:17 Research shows that of 140 respondents in SMA I Kota Gorontalo ie students with high pornographic exposure amounted to 88 (62.9%) there are 57 (39.6%) students at risk and who are not at risk 31 (48.4 %) students with low level of attachment were 52 (37.1%) students who were 6 (23.4%) and those who did not have sexual risk 46 (28.6%)

Whereas from 106 respondents in SMA I Tibawa that is high exposure students as much as 48 (45,3%) students whose attachment is low, no 58 (48,2%) high risk of exposure high 58 exposure (54,7%) 18 (8.2%) and non-sexual risk 30 (39.8%).

From the above data shows that of the above data shows that the data analysis using *chi square* statistical test on a table 4:17 then obtained X^2 count 37.425 because X^2 count > X^2 tables 3.84 and the p-value (0.000 < a.0,05) This means that H_0 is rejected and H_a accepted. Means there is a relationship between exposure to pornography and risky sexual behavior In SMA 1 City Gorontalo 2015.

From the above data shows that the data analysis using statistical test *Chi squer* at 4:22 table above, obtained X^2 count 26.199 therefore X^2 count > X^2 tables and indigo p (0.000 < 0.05) this means H_a accepted and H_0 rejected, means there is a relationship between exposure to pornography and risky sexual behavior In SMA I Tibawa in 2015

Ecology Research Center for Health Research, Health Research Board, MOH in 1990 to students in Yogyakarta said that the main factors that influence teenagers to engage in intercourse is: read books and watch movies porn blue / *blue film* is 49.2%. The main motivation for intercourse is likes (75,6%), biological needs 14-18% and feel less obedient to religion value 20-26%. Center criminology studies Islamic University of Indonesia in Yogyakarta found 26.35% of the 846 events of the wedding had had sexual relations before marriage which over 50% of which result in a pregnancy. (Endarto and Purnomo, 2000)

technological advances that are actually expected to provide ease in communicating, now has many more functions, such as access to kedia pornography. Many children and adolescents in schools use HP and cell phones access images or pornographic shorts and mentally destructive teenagers. As for examples of material that features sex is a picture or photo of a woman who is clad in skimpy or not clothed in front of or inside a magazine or print media, sex scenes in romantic movies on television, video or compact disc (DVD) movies and so on. (Nuryani and pratami, 2011)

Pornography exposure is very influential for risky sexual behavior, because if we look at pornographic videos, adult magazines or adult films, the sex drive increased and eager to engage in sexual behavior, regardless of the impact of risky sexual behavior, students whose accessibility is more sexual risk because, they often see pornographic videos, so they want to engage in sexual behavior, whereas for students who have a low level of attachment many are not at sexual risk, because they are not exposed to pornography,

2. Parents attention

parents have various roles and functions, one of them is parenting, in parenting according to Darmasih states that "parenting is the interaction of children and parents to educate, guide, and discipline and protect children to achieve maturity in accordance with the norms that exist in society.

Parental accompaniment is manifested through the way parents educate parents in educating their children. The way parents educate their children is called a parenting pattern. Interaction of children with parents, children tend to use certain ways that are considered the best for the child.

Based on the results of previous studies E ndang (2002) on SLTPN students in Depok and research wahyuni (2004) pad SMU 36 East jakarta parents should first provide sexual knowledge to their children through parent communication can explain the norms and provisions on matters things that can and should not be done by a teenager against the opposite sex.

Based on Table 4:18 Research results show that from 140 samples in SMA I Kota Gorontalo, attention of elderly enough as much as 81 (54,7%) and risk sexual behavior 27 (36,5%) who do not have sexual risk 54 (44, 6%) parents' attention was less than 59 (45,3%) students who had sexual risk 36 (26,6%) and who did not have sexual risk 23 (32,5%) while from research result at SMA I Tibawa from 106 samples, parents care enough 64 (55,7%) with sexual risk 8 (7,1%) and non-sexual risk 34 (34,9%) and parent attention less than 42 (39,6%) 10 (10,9%) and non-sexual risk 54 (53,1%)

From the above data shows that the data analysis using *chi square* statistical test on a table 4:17 then obtained X^2 count 10,570 because X^2 count $> X^2$ tables 3.84 and the p-value (0.002 $<$ a.0,05) This means that H_0 is rejected and H_a accepted. Means there is a relationship between the attention of parents with risky sexual behavior In SMA I Kota Gorontalo Year 2015.

From the above data shows that the data analysis using statistical test *Chi squer* at 4:23 table above, obtained X^2 count 0,211 because X^2 count $< X^2$ tables 3.84 and a p-value (0.846 $>$ 0.05) this means H_0 is accepted and H_a is rejected, meaning there is no relationship between parental attention and risky sexual behavior In SMA I Tibawa 2015.

Every attempt was made in educating children, absolute preceded by the appearance of the attitudes of parents in parenting include Behavior exemplary Every behavior is a behavior that is mechanical, but must be in base to the realization that the behavior will be a land of imitation and identification for their children .

The attention of parents is very influential, because students who are less attention from their parents, will be more widely interconnected so easy to fall into the things of sexual behavior, whereas if enough attention parents or students who are often noticed by parents, will not behave sexually risky, because between children and parents communicate with each other about sexual and parents are often concerned about the existence of their children.

3. Environment

In the process of social development, children also automatically learn the process of adjustment with the environment, both in the family environment and community environment. Individual social development is highly dependent on the individual's ability to adapt to his or her lingkunganya as well as the skills to overcome the problems facing him.

The result of the study of 140 students in SMA I Kota who live in good environment 67 (47,9%) who had sexual risk 28 (30,2%) and who did not have sexual risk 39 (36,9%) and student stay in bad environments as many as 73 (52.1%) are sexually risk while from 106 samples in SMA I Tibawa who live in good environment as many as 59 (55.7%) who are 8 (8.0%) 34 (34.9%) and students living in poor neighborhoods were 47 (44.3%) who had sexual risk 10 (10.9) and those who were not at risk 54 (53.1%)

From the above data shows that the data analysis using *chi square* statistical test on a table 4:19 then obtained X^2 count 0,535 because X^2 count $< X^2$ tables 3.84 and p value (0575 $>$ a.0,05) This means that H_0 accepted and H_a rejected. Means there is no relationship between environment with risky sexual behavior In SMA I Kota Gorontalo Year 2015.

From the above data shows that the data analysis using statistical test *Chi squer* at 4:24 table above, obtained X^2 count 0,000 because X^2 count $< X^2$ tables 3.84 and a p-value (1.000 $>$ 0.05) this means H_0 accepted and H_a rejected, meaning there is no relationship between environment with risky sexual behavior In SMA I Tibawa in 2015.

Moctar 2011 study results from NGO Shara Indonesia from 2000 to 2002, it is known that the most frequent place to have sexual intercourse is boarding house of 51.5% private house 30%, hotel or guesthouse 11.2% of area 2, 5% recreation places 2.4% in the classroom and others.

The environment is everything that exists around the individual, whether physical, biological, or social. The environment affects the process of entering knowledge into the individuals residing within the environment.

4. age of puberty

At the end of school age, the child immediately enters a period called "puberty" (derived from the Latin word "pubescere", meaning getting pubic hair), the early period of sexual maturation. In the course of a person's developmental process, puberty has no clear place .

The results of the 140 studies in SMA I Kota who experienced normal puberty were 62 (44.3%) with sexual risk 31 (35,1%) and non-risk 47 (42,9%) and students who experienced abnormal puberty as many as 78 (55.7%) and 32 (27.9%) non-sexual risk 32 (27,9%) non-sexual risk 30 (34,1%) moderate from 106 samples in SMA I Tibawa with normal puberty 35 (35,0%) 6 (5.9%) and non-sexual risk 29 (29.1%) students who experienced abnormal puberty were 71 (71.0%) who were 12 (12.1%) and those who did not have sexual risk risk 59 (58.9%)

From the above data shows that the data analysis using *chi square* statistical test on a table 4:20 then obtained X^2 count 1,966 because X^2 count $<X^2$ tables 3.84 and a p-value (0.218) $> a.0,05$) This means that H_0 accepted and H_a rejected. Means there is no relationship between puberitas with risky sexual behavior In SMA I Kota Gorontalo Year 2015

From the above data shows that the data analysis using statistical test *Chi squer* at 4:25 table above, obtained X^2 count 0,001 because X^2 count $<X^2$ tables 3.84 and indigo p (1.000) > 0.05) this means H_0 accepted and H_a rejected, meaning there is no relationship between puberty and risky sexual behavior In SMA I Tibawa in 2015

The results of Affandi's research in 1991 stated that there was an acceleration of puberty for women, now at the age of 12 years or less puberty has occurred in women Puberitas as a sign of early youth is no longer valid as a benchmark categorization of adolescents because of age of puberty which previously occurred in 15 -18 years now occurs in the early teens even before the age of 11 years.

Students who are dating under 16 years of age are at increased risk of sexual dating due to unhealthy dating, while those who are above 16 years of age experience normal puberty, as adolescents already know a lot of risky sexual behavior.

5. Friend

In the social development of adolescents then teenagers will separate themselves from parents and begin to expand relationships with peers. in general, adolescents become members of peer age group (*peer group*). peer groups become so meaningful and very influential in teenage social life

The result of the study of the number of Samples 140 students in SMA I Kota Gorontalo who have good friends as much as 54 (54,0%) who are 21 (24,3%) sexual risk that is not sexual risk 33 (29,7%) and student have 86 (86.0%) negative friends who have sexual risk 42 (38,7%) who have no sexual risk 44 (47,3%) from the research result of SMA I Tibawa who have good friend 83 (78, 3%) at 14 (14.1%) non-risk sexual risk 69 (68.9%) and who had poor friends of 23 (21.7%) who were 4 (4%) and 4 no sexual risk 19 (19.1%).

From the above data shows that the data analysis using *chi square* statistical test on a table 4:21 then obtained X^2 count 1,326 because X^2 count $<X^2$ table 3.84 and the value of p (0.328) $> a.0,05$) this means H_a rejected and H_0 received. Means there is no relationship between friends with risky sexual behavior In SMA I Kota Gorontalo Year 2015.

From the above data shows that the data analysis using statistical test *Chi squer* at 4:26 table above, obtained X^2 count 0,003 because X^2 count $<X^2$ tables and indigo p (1.000) > 0.05), this means that H_0 accepted and H_a rejected, meaning there is no relationship between friends with risky sexual behavior At SMA I Tibawa in 2015

Public Health The role played by peers in social life encourages young teens to form a peer age groups, these groups may be a group that besara because many of its members, which is referred to as *the crowd* but Dapa small group also referred to as *a clique*. because the number of members is small, then the click will have higher group cohesion. In the formation of the group will also be

followed also with the behavior of group conformity. in which teenagers will try to be able to adjust and integrate with the group so that they can be received in their group.

CONCLUSION

Based on the results of research and discussion in the described it can be drawn conclusion that is as follows:

There is a difference Risky Sexual Behavior In Teens Sek though students in urban and rural areas.

THANK-YOU NOTE

Praise gratitude of the writer praying to the presence of Allah Almighty, for his blessings and graces, the writer can complete this Research with the title "The Difference of Sexual Behavior at Risk in School Teens in Urban and Rural in Gorontalo Year 2015".

This research is not present at all, the authors are grateful to those who play a very important role in providing support and support both morally and materially. Without touching their hands and minds. To that end on this occasion the authors extend their sincere thanks and appreciation to:

All the parties who help either directly or indirectly in the completion of this Research The author realizes that this research is still far from perfection, this is not independent of the limitations of the author's knowledge, For that, the author expects suggestions and criticism yan constructive for the perfection of this research and hopefully this research can be useful for all of us, may Allah SWT always give love and his gift to us

REFERENCE

- Ali, Mohammad & Asrori Mohammad .2006. Psikologi Remaja. PT bumi Aksara. Jakarta
- Banun,Sari Oktavia Fadia Setyorogo Soedijono .(2013). Faktor-faktor yang berhubungan dengan perilaku seksual pranikah pada mahasiswa semester V Stikes X jakarta Timur 2012 ; Jurnal ilmiah Kesehatan ,5(1) : januari 2013
- Endarto, Yulian dan Purnomo sigit parmadi.(2009). Hubungan tingkat pengetahuan tentang kesehatan reproduksi dengan perilaku seksual berisiko pada remaja di SMK Negeri Yogyakarta ; jurnal kesehatan masyarakat.
- Humonggio, Irfan S. (2011),Peran Pik Remaja / Mahasiswa dalam usaha meningkatkan ketahanan remaja di kota gorontalo; di akses 21 desember 2015
- Komisi, Penanggulangan Aids Provinsi Gorontalo ; HIV/AIDS dan infeksi menular seksual lainnya di kota gorontalo; KPA Kota gorontalo ; 2015
- Marcopitz,Hal.2007. Gallub Youth Survey; Isu dan Tren utama remaja dan seks. Mason crest publish her, bandung.
- Sarwono,Sarlito wirawan .2011. psikologi remaja. Raja grapindo persada. Jakarta
- Setyowati, dewi (2012),Gambaran perilaku pranikah pada mahasiswa perilaku seksual pranikah di uneverstias semarang ;jurnal unimus 2012

ANALYSIS OF USE OF HEALTH CARE SERVICE IN JKN PROGRAM BY PARTICIPANTS PBI

"EDUCATIONAL CHALLENGES AND STRATEGIES OF HIGHER EDUCATION IN HEALTH ACHIEVEMENT OF SDGS 2030"

Rian Arie Gustaman, Kamiel Roesman Bachtiar



Abstract

One of the findings in the evaluation of the implementation of the National Health Insurance (JKN) in the first 2 years was the high ratio of claims on advanced outpatient services at the Advanced Medical Facility (FKTL). Data as of November 2014 shows the number of registered Non- Mandiri participants totaling 7,036,200. Non-PBI participants who use 1.6 million (23%) of health services. The cost of health services absorbed is 7.9 trillion rupiah. The data shows that the cost of mental health service in non PBI Mandiri participants is Rp282,139.00, much higher than the average per person per month amounted to Rp27,062.00. Claim rate on Non PBI Mandiri pool is 1380%. This is inversely proportional to the PBI participants whose utilization of health service is still well below what should be with a very low claim ratio. The specific purpose of this research is to analyze the utilization pattern of JKN-era health financing collateral to the PBI participants to know the description of the determinant that influences it. So as to produce Recommendations on the improvement of public health policy of informal sector non kin and kin which is expected to support the expansion of participation to the public health community. This research uses qualitative approach research. According to Moleong (Bungin, 2010), a qualitative approach is a process of research and understanding based on a methodology that investigates a social phenomenon and human problems. In this study, researchers create a complex picture, examine the words, detailed reports from the views of respondents, and conduct studies on natural situations. Based on the result of survey analysis which has been done to 6 participants, the knowledge about the perception of society about JKN program is influenced by the level of participant's education, the participant's participation in the organization, and the extension of the JKN program. Attitude visible from the community contained in the survey site, namely the balance between positive and negative attitude. In that place there are some people who only know without direct action to address the JKN program, there are also people who already know and able to use from the usefulness of JKN program. The conclusion in this research is for the state of society related to the practice of using the JKN program, it is clear the existence of the card empowerment by the society. However, there are still some people who have not used the function of the JKN program. This can be caused by the inappropriateness between knowledge with attitude and lack of special monitoring from health personnel so that the assumption formed that lack of understanding of it so that the form of bad practice. Whereas the usefulness of the JKN program is very useful for the surrounding community.

The Relationship Among Knowledge and Motivation with Smoking Behavior of Adolescent at SMKN 3 Gorontalo City.

Edwina R Monayo, Kevin E. Tololiu

"EDUCATIONAL CHALLENGES AND STRATEGIES OF HIGHER EDUCATION IN HEALTH ACHIEVEMENT OF SDGS 2030"



Tobacco smoke contains more over 4,000 chemicals, many of which are very harmful to our bodies and can cause adverse effects for smokers and the people around him. According to the data from The Tobacco Atlas (2015), Indonesia ranks first in the world for men smoking most aged over 15 years (66%). Gorontalo is the fourth province with the highest number of smokers in Indonesia (26.8%). The research aims at understanding the relationship among knowledge, motivation and smoking behavior of adolescent at SMKN 3 Gorontalo City.

The research applies crosssectional design with exact fisher test. Research population is 553 male students and sampling is completed to 79 students. Sampling applies purposive sampling.

From the results of the study showed that respondents who have a good level of knowledge about smoking for 98.7%, while 1.3% of respondents who have less knowledge. When viewed from the aspect of motivation, 86.1% of respondents with high motivation for smoking and 13.9% of respondents who have low motivation. Respondent's motivation was divided into high motivation for 86,1 % and low motivation for 13,9 %. Respondent's behavior was divided into high behavior for 74,7 % and moderate behavior for 25,3 % .

It can be concluded that there has not been relationship between knowledge and smoking behavior of adolescent for $p = 1.000$ ($\alpha > 0,05$) and there has been relationship between motivation and dmoking behavior of adolescent for $p = 0,026$ ($\alpha < 0,05$). It is recommended to government city of Gorontalo to motivate adolescent in terms of decreasing smoking interest for the adolescent.

Keywords : Smoking, knowledge, motivation

ABSTRACT

ANALYSIS OF NEONATAL COMPLICATIONS RISK FACTORS IN GORONTALO DISTRICT

"EDUCATIONAL CHALLENGES AND STRATEGIES OF HIGHER EDUCATION IN HEALTH ACHIEVEMENT OF SDGS 2030"



Wahyuni Hafid

Email : wahyunihafid292@gmail.com.

Hp : 082393949015

Background: Neonatal complications are complications experienced by newborns with the primary cause of maternal complications during pregnancy and childbirth. The complications experienced by infants such as asphyxia (failure spontaneous breathing), hypothermia and hipetermi, low birth weight, dehydration, jaundice, infection/sepsis, and tetanus.

Objective: To know the risk factors and the most significant factors of neonatal complication incidence in Gorontalo District 2017 years.

Methods: This research is a quantitative research that is analytic through case control approach. The study samples were all babies born alive with neonatal complications in Gorontalo District, which amounted to 516 babies. Purposive Sampling Technique.

Results: The risk factor the incidence of neonatal complications obtained by statistical analysis with Odd Ratio test is maternal age (OR=1,965) $p=0,000$, Parity (OR=1,430) $p=0,043$, Antenatal visits (OR = 2,496) $p=0,000$, and Energy Chronic Deficiency (OR = 30,359) $p=0,000$. While premature rupture of membranes is a protective factor the incidence of neonatal complications (OR = 0.547) $p=0,275$. The results of logistic regression test showed that antenatal visits (OR 5,606; CI 95% (2,009-15,648), and maternal age (OR 2,195; CI 95% (1,378-3,498), antenatal visits (OR 2,619; CI 95% (1,656-4,141), energy chronic deficiency (OR 36,893; CI 95% (18,112-75,146) was the most risk factor in the incidence of neonatal complications.

Conclusions: maternal age, Antenatal visits, and Chronic Energy Deficiency are the factors that have the most significant effect on neonatal complications in Gorontalo district.

Keywords: *Complication, maternal age, Parity, Antenatal care, Chronic energy deficiency, premature rupture of membranes*

PRELIMINARY

Neonatal complications are complications experienced by newborns with the main cause of maternal complications during pregnancy and childbirth. The complications experienced by infants such as asphyxia (spontaneous failure of breath), hypothermia and hipetermi, low birth weight, dehydration, jaundice, infection / sepsis, and tetanus.

Neonatal mortality rate is the number of infants aged up to 28 days who died in a region at a certain time per 1,000 live births in the same region and time period. The high level of Neonatal Mortality Rate (NMR) is useful to describe 3 (three) qualities: Quality Antenatal Care (ANC)

Public Health Department - Sport And Health Faculty - Gorontalo State University

Service, Post Natal Service and Relief Relief Program and handling of Essential Neonatal Emergency Cases (Profile of Gorontalo Provincial Health Office 2014).

According to the World Health Organization (WHO) every year approximately 3% (3.6 million) of the 120 million newborns have asphyxia, nearly 1 million of these babies die. In Indonesia, of all infant deaths, as many as 57% died. Causes of death of newborns in Indonesia are low birth weight infants (29%), asphyxia (27%), traumalahir, tetanus neonatorum, other infections and congenital abnormalities (Rahmawati, et al., 2016).

According to Indonesia Demographic and Health Survey (SDKI) data, infant mortality rate is 34 deaths / 1000 live births. This infant mortality rate of 47% died in neonatal period, every five minutes there is one neonate who died. Causes of death of newborns in Indonesia, one of them asfiksiyaitu equal to 27% which is the cause of the 2 newborn deaths after the Low Birth Weight (LBW). The direct cause of newborn death was 29% due to low birth weight (BBLR), asphyxia (13%), tetanus (10%), feeding problems (10%), infections (6.7%), haematological disorders (5 %), and others (27%) (Rahmawati, et al., 2016).

Achievement of neonatal handling with complications increased from the year of 2013 which amounted to 51.47% to 59.68 in 2014. Despite the increase in performance, but there is still a considerable disparity between provinces. The highest achievement was obtained by Province of Bangka Belitung Islands with 92.21% followed by West Nusa Tenggara with 85.21% and Central Java with 84.56%. The three provinces with the lowest achievement are West Papua Province (3.34%), Papua (19.12%), and Southeast Sulawesi (23.17%) (Indonesia Health Profile, 2014).

Based on the results of Riskesdas, the highest number of neonatal deaths occurred in 59 districts in Gorontalo District, followed by Boalemo Regency with 41 neonates and the lowest of Pohuwato and North Gorontalo districts respectively as many as 17 dead neonates. But in the number of neonatal deaths, the highest occurred in Boalemo District and the lowest in Pohuwato District. This is because the population and the number of live births in Kabupaten Gorontalo are much higher than in Boalemo Regency, thus affecting the mortality rate compared to the number of live births in the Province of Gorontalo (Profile of Gorontalo Provincial Health Office 2014).

Public Health Department - Sport And Health Faculty - Gorontalo State University

In the last 5 (five) years, neonatal mortality rate (AKN) tends to fluctuate from 2010 to 2012 has increased. Whereas in 2012 AKN reached 11,7 / 1000 Birth of Life decrease continuously year

2013 until year 2014 with AKN reaching 9.8 / 1000 KLH (Profile of Health Office of Gorontalo Province, 2014).

Increased achievements of AKN are among others highest



Low Birth Weight (LBW) in 2011 by 39%, then asphyxia as much as 27%, the rest due to congenital abnormalities and others - others. This means that the condition of the mother's condition before and during pregnancy greatly determines the condition of the baby, as well as the increase that occurred in 2012. Problems and challenges at that time is to prepare the prospective mother to be really ready to conceive and give birth and maintain health so that it can protect the fetus and infants from infections (Profile of Gorontalo Provincial Health Office, 2014).

The highest neonatal mortality is caused by LBW which is 85 neonatal death with percentage 42,93%, LBW can be caused by maternal health condition during pregnancy and childbirth, especially inefficiency of pregnant mother that is not fulfilled and other related cause. The next highest number of deaths caused by Asphyxia is a condition in which newborns can not breathe spontaneously and regularly, this number reaches 43 neonatal deaths with a percentage of 21.72% (Profile of Gorontalo Provincial Health Office 2014).

Data obtained in Gorontalo District Health Office, in 2014 amounted to 6,821 with handling complications reached 372 infants (36.4%), in 2015 the number of handling incident complication 32.8%) of the total number of 6,714 infants, and in 2016 numbered 6,609 live births with neonatal complication of 489 infants (45.1%) (District Health Office of Gorontalo, 2015). Based on the above data with the high prevalence of neonatal complications in Indonesia, and since there are still differences in findings on factors causing the incidence of complications in neonatal, and still lack of research on complications in neonatal Gorontalo Province, the researchers are interested in doing research on risk factor analysis of the occurrence of complications neonatal in Gorontalo District in 2017. METHOD The type of research used Case Control. Case Control is a study of risk factors using a retrospective approach, meaning that the study begins by identifying the affected group of disease or certain effects (cases) and the group without effects (control), then identifying risk factors occurring in the past, so as to explain why the case is affected, while the control is not affected (Riyanto, 2011). Case groups are those who suffer from the disease or are affected by the research. The control group were those who did not suffer or were not affected by the results studied. In the case-control study, case groups were selected to compare with the control group by observing

existing or past exposures that were considered to be sufficiently relevant to the nature of the disease as well as the conditions under study. This research was conducted at all health centers located in Gorontalo District. The population in this study was divided into two groups: case and control. The case is a live birth baby with complication incidence in Gorontalo District in 2016 as many as 258 people. While Control is a live birth baby with no complications in Gorontalo District Year 2016 as many as 258 people. obtained by purposive sampling technique. The dependent variable is the incidence of neonatal complications. Independent variables are parity, antenatal visit, chronic energy deficiency and premature rupture of membranes. The data were analyzed using simple logistic regression test for bivariate test, and multiple logistic regression test for multivariate test to see the variables that have a very strong effect on the incidence of neonatal complications at the Puskesmas located in Gorontalo District in 2017. The independent variables and dependent variables are said to be there is significant influence if p significance level $<0,05$. While to see whether the variable can enter as a candidate for multivariable test then the value $p = <0.25$. RESEARCH RESEARCH Bivariate Analysis The results of simple logistic regression analysis showed that maternal age was significantly associated with neonatal complication incidence with p value = 0,000, OR = 1,965 (95% CI LL-UL = 1,358-3,842) which can be seen in the following table :

Table 1 Maternal Mortality Risk Analysis of Neonatal Complications in Gorontalo District 2017

Umur Ibu	Komplikasi Neonatal				Prosentase
	Kasus		Kontrol		
	N	%	N	%	
Risiko Tinggi (<20 & >35 ttn)	109	42,2	70	27,1	179 (34,7)
Risiko Rendah (20-35 thn)	149	40,0	188	72,9	337 (65,3)
Total	258	100	258	100	516 (100)
$p = 0,000, OR = 1,965 (1,358-3,842)$					

The result of simple logistic regression analysis showed that parity correlated significantly with incidence of neonatal complication with p value = 0,043, OR = 1,430 (95% CI LL-UL = 1,011-2,022) which can be seen in the following table:

Table 2 Parity Risk Analysis of Neonatal Complications in Gorontalo District 2017

Paritas	Komplikasi Neonatal				Prosentase
	Kasus		Kontrol		
	N	%	N	%	
Risiko Tinggi (>2 anak)	138	53,5	115	44,6	253 (49,0)
Risiko Rendah (<2 anak)	120	46,5	143	55,4	263 (51,0)
Total	258	100	258	100	516 (100)
p = 0,043, OR = 1,430 (1,011-2,022)					

The results of simple logistic regression analysis showed that the ANC visit was significantly associated with the incidence of neonatal complications with p value = 0,000, OR = 2,496 (95% CI LL-UL = 1,727-3,607) which can be seen in the following table:

Table 3 Risk Analysis of ANC Visit to Neonatal Complications in Gorontalo District 2017

Kunjungan ANC	Komplikasi Neonatal				Prosentase
	Kasus		Kontrol		
	N	%	N	%	
Risiko Tinggi (<4 Kali)	123	47,7	69	26,7	192 (37,2)
Risiko Rendah (>4 Kali)	135	52,3	189	73,3	324 (62,8)

Rendah
(>4 Kali)

Total	258	100	258	100	516 (100)
p = 0,000, OR = 2,496 (1,727-3,607)					



The result of simple logistic regression analysis showed that the history of KEK was significantly associated with neonatal complication with p value = 0,000, OR = 30,359 (95% CI LL-UL = 15,410-59,810) which can be seen in the following table:

Table 4 Risk Analysis of SEZ Section to Incidence of Neonatal Complications in Gorontalo District in 2017

Riwayat KEK	Komplikasi Neonatal				Prosentase
	Kasus		Kontrol		
	N	%	N	%	
Risiko Tinggi (LILA <23 cm)	142	55,0	10	3,9	152 (29,5)
Risiko Rendah (LILA >23 cm)	116	45,0	248	96,1	364 (70,5)
Total	258	100	258	100	516 (100)
p = 0,000, OR = 30,359 (15,410-59,810)					

The results of simple logistic regression analysis showed that the early breakage of membranes did not correlate significantly with the incidence of neonatal complications with p value = 0.275, OR = 0.547 (95% CI LL-UL = 0.181-1.654) which can be seen in the following table:

Table 5 Risk Analysis of KPD History on Neonatal Complications in Gorontalo District 2017

Riwayat KPD	Komplikasi Neonatal		Prosentase
	Kasus	Kontrol	

	N	%	N	%	
Risiko Tinggi (KPD)	5	1,9	9	3,5	14 (2,7)
Risiko Rendah (TDK KPD)	253	98,1	249	96,5	502 (97,3)
Total	258	100	258	100	516 (100)
p = 0,275, OR = 0,547 (0,181-1,654)					

Multivariate Analysis

Multiple logistic regression is useful to know which independent variables have the strongest effect on the incidence of neonatal complications.

In this multivariate analysis is expected to come out a final result that can predict the determinant factors that affect the incidence of neonatal complications. The result of independent variable selection can be seen in the following table:

Table 6 Independent Variable Selection To Proceed to Multivariate Analysis

No	Variabel	p value
1	Umur ibu	0,000*
2	Paritas	0,043*
3	Kunjungan ANC	0,000*
4	Riwayat KEK	0,000*
5	Ketuban Pecah Dini	0,275

* is removed from the model (p> 0.25)

Based on the results of bivariate selection test found 4 of 5 variables that can be included in the multivariate analysis including maternal age, parity, visit ANC, KEK history.

Public Health Department - Sport And Health Faculty - Gorontalo State University

In the final stage of multivariate test three variables were found to have a very strong effect of neonatal complications, as follows:

Table 7 Final Results of Multivariate Analysis Using Multiple Logistic Regression

Variabel	B	Wald	p
Umur Ibu	0,786	10,938	0,000
Kunjungan ANC	0,963	16,951	0,000
Riwayat KEK	3,608	98,806	0,000

HIGHER EDUCATION IN HEALTH ACHIEVEMENT OF SDGS 2030" IS-HE

DISCUSSION

1. Influence of Mother Age Against Neonatal Complications

From the result of bivariate statistic analysis obtained p value = 0,000, then there is said to have a significant influence between mother age with the incidence of neonatal complication with OR = 1,965 value, which means the age of women at risk 1,965 times to the incidence of neonatal complications with lower limit value = 1.358 and upper limit = 3,842 (not exceeding 1) so maternal age is a risk factor for neonatal complication.

This research is in line with research conducted by Simbolon (2008). The result of multiple logistic regression analysis showed that there was a correlation between maternal age and neonatal sepsis. Babies born to mothers of <20 and> 35 years of age are at risk of developing sepsis neonatorum 7,595 times compared with infants born to mothers of 20-35 years of age.

2. Influence of Parity Against Neonatal Complications

Parity is a woman's condition with respect to the number of children born. Women with high parity are women who have > 2 children and low parity ie <2 children. Parity 2-3 is a safe parity in terms of maternal mortality. maternal mortality (Walyani, 2013).

From the result of bivariate statistic analysis obtained value p value = 0,043, hence there is said significant influence between parity with incidence of neonatal complication with value OR = 1,430 which mean risky parity 1,430 times to incidence of neonatal complication with lower limit value = 1.011 and upper limit = 2.022 (not exceeding 1) so that parity is a risk factor for neonatal complication.

This study is in line with the study of Young sori and Fransiska (2013) which shows that parity has a significant relationship and affects the incidence of neonatal. Results OR = 0.483, from the analysis obtained on the proportion of cases having more than 1 parity of 20 Orang (40%) and control 29 people (58%). While those who have parity less than or equal to one in the case of 30 people (60%) and control 21 people (42%). With statistical test result χ^2 obtained p value = 0,072 ($p > 0,05$).

3. The Influence of ANC Visit To The Incidence Of Neonatal Complications

Pregnancy or ANC examination is a physical and mental examination of pregnant women and saves mothers and children in pregnancy, childbirth and the puerperium, so that their post-partum state is healthy and normal, not only physically but mentally (Wiknjosastro, 2005). Integrated antenatal care is the integration of routine antenatal care with some other programs targeting pregnant women, as per the priorities of the Department of Health, needed to improve the quality of antenatal care (Padila, 2014).

From the result of bivariate statistic analysis obtained p value = 0.000, hence there is said significant influence between visit of ANC with incidence of neonatal complication with OR value = 2,496 which mean visit ANC risk 2,496 times to incidence of neonatal complication with lower limit value = 1,727 and upper limit = 3,607 (not exceeding 1) so ANC visit is a risk factor for neonatal complication.

This study is in line with the Septiani study (2014) that women who had antenatal visits 1-3 times during gestation were 1.3 times more likely to deliver LBW than those who visited > 4 (95% CI 1.10-1, 52).

4. Effect of SEZ History on Neonatal Complications Occurrence

Chronic Energy Deficiency (KEK) is a condition of mothers who suffer from a shortage of food that lasts chronic (chronic) resulting in the occurrence of health problems in the mother. SEZ can occur in women of childbearing age (WUS) and pregnant women (Irianto, 2014).

From the result of bivariate statistic analysis obtained p value = 0,000, then there is said there is significant influence between history of KEK with incidence of neonatal complication with OR value = 30,359 which mean KEK risk 30,359 times to incidence of neonatal complication with lower limit value = 15,410 and upper limit = 59,810 (not exceeding 1) so SEZ's history is a risk factor for neonatal complication.

This study is not in line with research conducted by Festy (2010) which shows that LILA <23.5 cm hence the tendency to have Low Birth Weight Baby will be 6,307 times more than LILA mother > 23,5 cm.

5. Influence of Early Neonatal Complications of Neonatal Complications

Early rupture of membranes is defined as premature rupture of the membranes. This may occur late in pregnancy or long before delivery. Preterm KPD is premature rupture of membranes before 37 weeks' gestation. The elongated KPD is premature rupture of membranes that occur more than 12 hours before the time of delivery. The incidence of KPD ranges from 5-10% of all births, and preterm KPD occurs in 1% of all pregnancies 70% of cases of KPD occur in a term pregnancy. KPD is the cause of 30% premature birth (K Sukarni, et al., 2013). From result of bivariate statistic analysis got value p value = 0,275, hence there is no influence between history of premature breakup of membrane with incidence of neonatal complication with OR = 0,547 which means history of premature rupture of membranes only risk 0,547 times to incidence of neonatal complication with lower limit value = 0.181 and upper limit = 1.654 (past the number 1) so that history of premature rupture of membranes is not a risk factor for neonatal complication events. This study is not in line with research conducted by Simbolon, 2008 based on the status of membranes in the case of more than half (58.8%) of the membrane status is premature rupture of membranes (KPD), whereas in the control group sebgian (82.4%) state water membranes not KPD. The results of multiple logistic regression analysis showed an association of amniotic status with neonatal sepsis. Infants born to mothers with KPD were at increased risk of sepsis neonatorum 7,595 times compared with babies born to mothers not KPD. KPD is the rupture of the membranes before any signs of labor

CONCLUSION

1. There is a significant influence between maternal age factors on the incidence of neonatal complications in Kabupaten Gorontalo.
2. There is a significant influence between the parity factor on the incidence of neonatal complications in Gorontalo District.
3. There is a significant influence between ANC visitation factors on the incidence of neonatal complications in Kabupaten Gorontalo.

4. There is significant influence between history factor of KEK to incidence of neonatal complication in Kabupaten Gorontalo.
5. Maternal age, ANC visit, and history of KEK are the factors that have the strongest influence on neonatal complications in Gorontalo District.

ACKNOWLEDGMENTS Thanks to all those who have assisted in conducting this research

REFERENCE

- Abdullah, A Zulkifli. Dkk. 2012. *Faktor Risiko Kematian Neonatal Dini di Rumah Sakit Bersalin. Kesehatan Masyarakat Nasional* Vol. 6, No. 6, Juni 2012.
- Agus, Riyanto. 2011. *Aplikasi Metodologi Penelitian Kesehatan*. Nuha Medika. Yogyakarta.
- Dewi, Vivian. 2014. *Resusitasi Neonatus*. Salemba Medika. Jakarta.
- Dikes. 2016. Data Dinas Kesehatan Kabupaten Gorontalo. 2014, 2015 dan 2016.
- Festy, P. 2010. *Analisis Faktor Resiko Pada Kejadian Berat Badan Lahir Rendah Di Kabupaten Sumenep*.
- Irianto, K. 2014. *Gizi Seimbang dalam Kesehatan Reproduksi*. Cetakan Pertama. Alfabeta, cv. Bandung.
- Irmayani, St. 2016. *Pengaruh Umur, Komplikasi Lain Dan Jenis Persalinan Dengan Asfiksia Bayi Baru Lahir Pada Ibu Preeklamsia Berat Di Rsud Mataram Tahun 2013-2014*. Jjunal Kesehatan Prima Vol. 10 No. 1, Februari 2016.
- K Icemi, Sukarni dan P Wahyu. 2013. *Buku Ajar Keperawatan Maternitas*. Medika Book.
- Kemendes, 2014. *Profil Kesehatan Indonesia*.
- Manuaba. 2008. Ilmu Kebidanan, Kandungan Dan KB. Jakarta. EGC.
- Muda, S. 2014. *Faktor Risiko Kejadian Persalinan Prematur Di RSUD DR. Pirngadi Kota Medan Tahun 2010-2013*.
- Padila, 2014. *Buku Ajar Keperawatan Maternitas*. Nuha Medika. Yogyakarta.
- Prasetyawati, Arsita. 2012. *Kesehatan Ibu Dan Anak (KIA) Dalam Millineum Development Goals (MDGs)*. Nuha Medika. Yogyakarta.
- Putra, S Rizema. 2012. *Asuhan Neonatus Bayi Dan Balita Untuk Keperawatan Dan Kebidanan*. Yogyakarta: D-Medika.
- Profil Dinas Kesehatan Provinsi Gorontalo. 2014.

- Rahmawati, Lisa. Dkk. 2016. *Factor-Faktor Yang Berhubungan Dengan Kejadian Asfiksia Pada Bayi Baru Lahir Di Ruang Medical Records RSUD Pariaman*. Prodi D III Kebidanan Poltekes Kemenkes Padang.
- Rustam, 2005. *Sinopsis Obstetri Jilid I*. Jakarta. EGC
- Saifuddin, A Bari. 2006. *Buku Acuan Nasional Pelayanan Kesehatan Maternal Dan Neonatal*. Yayasan Bina Pustaka Sarwono Prawirohardjo. Jakarta.
- Sastroasmoro, Sudigdo dkk. 2010. *Dasar-Dasar Metodologi Penelitian Klinis edisi ketiga*. In: Pemilihan Subjek Penelitian Dan Desain Penelitian. Jakarta: Sagung Seto.
- Simbolon, D. 2008. *Faktor Risiko Sepsis Pada Bayi Baru Lahir Di RSUD Cukup Kabupaten Rejang Lebong*. Politeknik Kesehatan Bengkulu. Vol. 36, No. 3, 2008:127-134.
- Stedman. 2003. *Kamus Ringkas Kedokteran Stedman Untuk Profesi Kesehatan*. Jakarta: EGC.
- Varney. 2006. *Buku Ajar Asuhan Kebidanan*. Jakarta. EGC.
- Vitriyani, Eka dkk. 2012. *Factor-Faktor Yang Berhubungan Dengan Pemeriksaan Antenatal Care (ANC) K1 Ibu Hamil Di Kecamatan Polokarto Kabupaten Sukoharjo*. Vol. 5, NO. 2, Desember 2012
- Walyani, E Siwi dan Purwoastuti, Th Endang. 2015. *Asuhan Kebidanan "Kegawatdaruratan Maternal & Neonatal"*. Yogyakarta : Pustaka Barupress.

ABSTRACT

***Hyperemesis gravidarum* EVENTS RISK FACTORS IN PREGNANT WOMEN IN GENERAL**

"EDUCATIONAL CHALLENGES AND STRATEGIES OF HIGHER EDUCATION IN HEALTH ACHIEVEMENT OF SDGS 2030"



Rahmawati ¹, Rifai Ali ²

Email: rahma.amma97@gmail.com

Hp: 085399521659

Background: *Hyperemesis gravidarum* is nausea and vomiting that occurs lebih of 3x daily and lebih weight loss of 5% of the weight before pregnancy. The incidence of HEG is approximately 10% of all pregnancies, in pregnancy the incidence of incidence varies from 6% to 19%. Whereas in preterm pregnancy the incidence is 2% of all pregnancies. Almost all of HEG in pregnancy will preterm birth before full term or delivery will occur within one week after membrane rupture. Approximately 85% perinatal morbidity and mortality caused by prematurity. HEG is associated with the cause of the incidence of prematurity with an incidence of 30-40%

Objective: to know the risk factors of *hyperemesis gravidarum* in pregnant women based on variables maternal age, education, parity, education and gestational age,

Method: this kind of research is observational analytic using *case control study* design, that can compare groups of case and control groups to determine the proportion. This study was done to determine the incidence of *hyperemesis gravidarum* in pregnant women (cases) and not the incidence of *hyperemesis gravidarum* in the mother Hamill (control group).

Result: The results showed that the risk factors for the incidence of *hyperemesis gravidarum* is Age ($OR = 1.127$), parity ($OR = 2.700$) and work ($OR = 1.188$). Education ($OR = 0.550$) and gestational age ($OR = 0.190$) was a protective factor against the incidence of *hyperemesis gravidarum*

Conclusion: From this study concluded that the risk factors *Hyperemesis gravidarum* p aling risk is parity.

Keywords: *Hyperemesis gravidarum*, parity, age, education, pregnant women

A. preliminary

Every year around 160 million women worldwide are pregnant. Most of these pregnancies take place safely. However, about 15% suffer from severe complications, with one third being a life-threatening complication of the mother. This complication results in the death of more than half a million mothers each year. Of this amount is estimated 90% occur in Asia and sub-Saharan Africa, 10% in other developing countries, and from 1% in developed countries. In some countries the risk of maternal mortality is higher than 1 in 10 pregnancies, whereas in developed countries this risk is less than 1 in 6,000¹.

One pen yebab cases of obstetric complications is *hyperemesis Gravidarum (HEG)*, which is an issue that is controversial in obstetrics. HEG often has consequences that affect both maternal and neonatal morbidity and mortality, particularly in high perinatal mortality, among others due to less than monthly deaths, and increased incidence of infection due to unfamiliar, old partus and frequent artificial partus in meet. In the management of HEG cases especially on conservative management².

Hyperemesis Gravidarum are nausea

Excessive vomiting so

cause interference with daily activities and may even endanger the lives of pregnant women³. Besides *Hyperemesis Gravidarum* also is nausea and severe vomiting causing daily work was interrupted, and the general condition becomes bad mother Nausea and vomiting often occur in 60-80% *primigravida*, this is a natural phenomenon and common in the first trimester of pregnancy Nausea usually occurs in the morning, but can also arise at any time and night. These symptoms experienced by 40 -60% *multigravida*. These symptoms occur approximately 6 weeks after the first day of the last menstrual period and last for approximately 10 weeks. In general, women are able to adapt to this situation, although the symptoms of severe nausea and vomiting that can last up to 4 months⁴

HEG complications may occur in the mother and fetus, as a mother would a lack of nutrients and fluids so that the physical condition of the mother becomes weak and tired, can also cause acid-base disorders, aspiration pneumonia, esophageal mucosal tear, damage to liver and kidney damage. This will affect the growth and development of the fetus because the nutrients are not being met or not in accordance with the pregnancy, which resulted in reduced fetal blood circulation as well as bleeding in the retina caused by increased blood pressure when p enderita vomiting⁵.

Public Health Department - Sport And Health Faculty - Gorontalo State University

Based on data from the Regional General Hospital Mongondow Bolaang south in 2015 the incidence of *hyperemesis gravidarum* in pregnant women were 30, while in 2016 the incidence of

Hyperemesis gravidarum in pregnant women numbered 21 people. So the total of all pregnant women experience *hyperemesis gravidarum* were hospitalized in obstetrics installation of years 2015-2016 as many as 51 people.

Based on the data obtained, this study aims to determine the risk factors of *hyperemesis gravidarum* in pregnant women based on variables maternal age, education, parity, education and gestational age.

B. Materials and Methods

This type of research used was analytic observational research using *case control study* design, that can compare groups of case and control groups to determine the proportion. This study was done to determine the incidence of *hyperemesis gravidarum* in pregnant women (cases) and not the incidence of *hyperemesis gravidarum* in the mother Hamill (control group).

In this study the researchers used a 1: 2 comparison with a case group of 51 HEG pregnant women and a control group of 51 HEG pregnant women (not HEG), who had the same age between cases and controls for all women who had HEG 102 oarng.

The research was done in March to April 2017. The study in public hospitals Mongondow Bolaang south.

Case: Pregnant women who experience *hyperemesis gravidarum* who visit a general hospital south Bolaang Mongondow years 2015-2016 as many as 51 people

Control: Pregnant women who do not experience *hyperemesis gravidarum* who visit a general hospital south Bolaang Mongondow years 2015-2016 as many as 102 people.

Sampling was done by *purposive sampling* technique.

C. Results

1.Univariate

From Table 1 it can be seen that of 153 (100%) samples *Hyperemesis gravidarum* events in hospitals Bolaang southern Mongondow years 2015 to 2016 had the highest rate in Control (*Hyperemesis gravidarum*) as many as 102 people (66.7%) and the lowest number in case (*hyperemesis Gravidarum*) were 51 people (33.3%).

B erdasarkan highest maternal age group in the age group <20 years as many as 50 people (32.7%) and the lowest in the age group 30-34 years as many as 11 people (7.2%). For pe ndidikan highest rate in the group of elementary school (SD) of 87 (56.9%) and the lowest in the group of high school (SMA) as many as 22 people (14.4%).

Most samples of his work are housewives (IRT) as many as 97 people (63.4%) and the lowest in the group of Honorary many as 22 people (14.4%).

Based on the highest parity in the parity group 1 child as much as 114 individuals (74.5%) and the lowest in the group of children as much as 12.4 parity 3 people (7.2%).

2. Bivariate

Table 2 Statistical analysis of bivariate test calculation of *odds ratio* values obtained OR = 1.127 lower limit-upper limit at 95% CI = 0.573 and the *upper limit* = 2,219 which means that advanced maternal age is a risk factor for the incidence of *hyperemesis gravidarum* in pregnant women, maternal age < 20 and ≥ 35 years had a substantial risk of 1.127 against *Hyperemesis gravidarum* in pregnant women compared to mothers aged 20-35 years

The results of the bivariate statistical analysis to test the calculation of *odds ratio* OR = 0,550 values obtained lower limit-upper limit at 95% CI = 0.279 and the *upper limit* = 1.086 which means the mother's education is a protective factor against the incidence of *hyperemesis gravidarum* in pregnant women.

A protective factor or factors are protective factors that can reduce the incidence of *hyperemesis gravidarum* in pregnant women, but the lower limit-upper limit is not significant.

Statistical analysis *Odds ratio* calculation test obtained by value OR = 2,700-upper limit lower limit at 95% CI = 1.318 and the *upper limit* = 5.530 which means parity is a risk factor for the incidence of *hyperemesis gravidarum* in pregnant women.

The results of the bivariate statistical analysis to test the calculation of *odds ratio* OR = 1.188 values obtained lower limit-upper limit at 95% CI = 0.585 and the *upper limit* = 2.408 which means that work is a risk factor for the incidence of *hyperemesis gravidarum* in pregnant women.

The results of the bivariate statistical analysis to test the calculation of *odds ratio* OR = 0.190 values obtained lower limit-upper limit at 95% CI = 0.114 and the *upper limit* = 0.317 which means that the pregnancy is a risk factor protective of *hyperemesis gravidarum* in pregnant women gestational age \leq 0-12 week has great risks .190 against *Hyperemesis gravidarum* in pregnant women compared $\geq 12-42$ weeks gestation.

D. Discussion

Paritas a risk factor for the incidence of *hyperemesis gravidarum* in pregnant women (OR = 2.700; CI = 1.318 and *the upper limit* = 5.530). Parity is the number of children who had been given birth by mothers seoran whether living or born mat i. Parity become *hyperemesis Gravidarum* terjandi risk factors caused by lack of experience and adjustment to physiological. We recommend that pregnant women with gestational primigravida parity for the first time experienced in order to eat little but often, avoid odors - smells that are not in love, when will wake up from the resting condition, should be done by slowly. and routine checkups so that a lot of counseling and advice from your midwife / health workers about nausea and vomiting.

Age (OR = 1,127) and work (OR = 1.188) as well as a risk factor *hyperemesis gravidarum*. In this study, maternal age variable, categorized into high-risk maternal age and low-risk mother's age. In hospitals south Bolaang Mongondow most pregnant women who have *hyperemesis gravidarum* at the age of 20-35 years compared with maternal age <20 and> 35 years. This is caused by the influence of other factors such as psychological factors, abnormalities in pregnancy, hormonal changes are not stable.

The majority of pregnant women with *hyperemesis gravidarum* occurs in women who do not work. This is due to the mothers who do not work in the psychological matters of saturation in the activities of household routines. Mothers should wherever possible activity / activities outside the home. In addition to the hardships of life that only rely on their husbands or because regularized boring housewife related to psychological factors as the factors triggering the occurrence of *hyperemesis gravidarum*.

In this study get that Age Pregnancy (OR = 0.190) and the level of education (OR = 0,550) into a protective factor against the incidence of *hyperemesis gravidarum*.

This study is in line with research conducted by Sari Siviana with the title of the relationship of risk factors of pregnant women with hyperemesis gravidarum in hospital ward obgyn Raden Mattaher jambi that is as much as 53% pregnant women with HEG with gestational age \leq 0-12 weeks. *Hyperemesis gravidarum* is more common in gestational age \leq 0-12 weeks due to rising levels of the hormone *human chorionic gonadotropin* (HCG) produced by the trophoblast cells of the blastocyst, especially in the first 2-11 weeks of pregnancy. HCG passes control of the pituitary and ovaries cause the corpus luteum continues to produce estrogen and progesterone to stimulate nausea and vomiting.

Maternal education is closely related to the level of knowledge of mothers, higher level of education obtained, the more patterns of knowledge and conversely the lower the person's education will hinder the development of attitudes toward new values introduced.

The education level of the sample in this study the majority (56.9%) were included in the category of primary education which results in lower absorption obstacles in health information so that the knowledge possessed also lower the impact on her life.

E. Conclusions and suggestions

The conclusions of this study was the incidence of risk factors is *Hyperemesis Gravidarum* Age (OR = 1.127), parity (OR = 2.700) and work (OR = 1.188). Education (OR = 0.550) and gestational age (OR = 0.190) was a protective factor against the incidence of *hyperemesis gravidarum*.

Suggestions importance of improving education levels in young women that upon admission during pregnancy, which was obtained enough knowledge can help them cope with *hyperemesis gravidarum*.

F. Thank-you note

Acknowledgments conveyed to the Director of Hospital Bolaang South Mongondow particularly employees in the medical record and kebidan for his help during the study period.

G. Bibliography

1. Prawiroharjo, Sarwono, "Maternal and Neonatal Care", Ybpsp, Jakarta: 2012. *Obstetrics*. Jakarta.
2. Saifuddin, AB, 2012. *National Maternal and Neonatal Health Service Reference Book, Mold Issue 1*. Jakarta: YBP Sp.
3. Manuaba. *Gynecology And Obstetrics KB*. Jakarta: EGC; (2010).
4. Wiknjosastro H. *Obstetrics*. Jakarta: Yayasan Bina Pustaka Sarwono Prawirohardjo; (2006).
5. Setiawan, A. (2007). *Midwifery Research Methods DIII, DIV, S1 and S2*. Yogyakarta: Nuha Medika

**Table 1 Sample Distribution by Age Pregnancy In Hospital
South Bolaang Mongondow 2015-2016**

No	Variables	n	%
1	Case control group		
	Case	51	33.3
	Control	102	66.7
	amount	153	100
2	Age (Year)		
	<20	50	32.7
	20 - 24	48	31.4
	25 - 29	26	17.0
	30 - 34	11	7.2
	≥ 35	18	11.8
	amount	153	100
3	Education		
	SD	87	56.9
	SMP	44	28.8
	SMA	22	14.4
	amount	153	100
4	Work		
	IRT	97	63.4
	entrepreneur	34	22.2
	Honorary	22	14.4
	amount	153	100
5	Parity		
	1	114	74.5
	2	20	13.1
	3	19	12.4
	amount	153	100

Table 2 Risk Analysis of Hyperemesis Gravidarum Occurrence at RSUD Bolaang Mongondow Selatan 2015-2016

No	Variables	Genesis <i>Hyperemesis Gravidarum</i>				Total		OR 95% CI LL-UP
		Case		Control		n	%	
		n	%	n	%	n	%	
1	Mother's Age							
	High risk	23	45.1	43	42.2	66	43.1	1,127
	Low risk	28	54.9	59	57.8	87	56.9	0,573 -
	amount	51	100	102	100	153	100	2,219
2	Education							
	High risk	24	47.1	63	61.8	87	56.9	0.550
	Low risk	27	52.9	39	38.2	66	43.1	0.279 -
	amount	51	100	102	100	153	100	1.086
3	Parity							
	High risk	36	70.6	48	47.1	84	54.9	2,700
	Low risk	15	29.4	54	52.9	69	45.1	1,318 -
	amount	51	100	102	100	153	100	5,530
4	Work							
	High risk	34	66.7	64	62.7	98	64.1	1.188
	Low risk	17	33.3	38	37.3	55	35.9	0.585 -
	amount	51	100	102	100	153	100	2,408
5	Pregnancy Age							
	High risk	51	100	12	11.8	63	41.2	0.190
	Low risk	0	0	90	88.2	90	58.8	0.114 -
	amount	51	100	12	11.8	63	41.2	0.317

SPATIAL – TEMPORAL ANALYSIS INCIDENCE OF DENGUE HEMORRHAGIC FEVER (DHF) AGAINST WEATHER VARIABLE IN LIMBOTO AND TELAGA BIRU DISTRICT, GORONTALO REGENCY YEAR 2012-2015

Ririn Pakaya

Department of Public Health, Universitas Gorontalo

Email: ririn.pakaya@mail.ugm.ac.id

Abstract

Background: Dengue Hemorrhagic Fever (DHF) is diseases caused by dengue virus. DHF is one of the main public health issues in Indonesia, even endemic in all province. DHF transmitted by mosquito bites from *Aedes* genus *Aedes*, mainly *Aedes aegypti*. DHF is emerging over the year and attacking all of age groups. It related to environmental condition and community behavior. DHF in Gorontalo has been endemic diseases every years and reported deaths of patient in this cases. Based on data of Districts Health Office Gorontalo, showed incidence of DHF has raised during last six years on 2010-2015. The extreme improvement DHF incidence on 2010 amounts 167 cases (3 person died) and the lowest reduction of DHF incidence on 2011 amounts 4 cases (1 person died). Gorontalo Province consists of 5 regency and Gorontalo Regency increase dengue cases significantly especially for Limboto district and Telaga biru district.

The objectives: This study aims to examine the pattern of the relationship among weather variables on the incidence of dengue hemorrhagic fever (DHF) in Limboto and Telaga Biru district for 4 years (2012-2015).

Method: This study was observational used cross sectional study design supported by Geographic Information System (GIS) for spatial information.

Result: Main result by poisson regression test showed association between weather variables for instance precipitation, temperature, humidity, wind velocity. Each variabels use in same months, previous months, and previous two months, respectively. Variable of precipitation, humidity, and temperature in previous two months showed weak coefficient correlation and negative.

Conclusion: The pattern of DHF incidence following fluctuation of weather variables. The results show that the District Health Office Gorontalo may considered weather factors on DHF's prevention program.

Keyword: *Incidence of DHF, Climate, Temporal*

Introduction

Dengue Haemorrhagic Fever (DHF) is a public health problem that tends to expand its distribution area, in line with increasing mobility and population density and followed by annual cycle pattern.¹

DHF in Gorontalo Regency has become endemic diseases every year and reported deaths of patient. DHF in Gorontalo has been categorized on vigilant level. Case of DHF has declared as extraordinary circumstances.² Over January until Desember 2014 reported amounts 269 cases of DHF in Gorontalo. Amounts of 13 person of DHF's patients was died. Case of DHF in Gorontalo showed improvement significantly, specialized on Limboto as government center of Gorontalo.²

Limboto District is the highest districts for dengue fever cases in 107 cases in 2010, 1 case in 2011, 35 cases in 2012, 49 cases in 2013, 34 cases in 2014, and 40 cases in 2015 and in Limboto District is found in 8 endemic villages of Bolihuangga, Bongohulawa, Hepuhulawa, Hunggaluwa, Hutuo, Kayu Merah, Kayu Bulan and Tenilo. Various efforts have been made by Health department of Gorontalo in overcoming DHF, but DHF case still remain high and difficult to be controlled. Telaga Biru is one of district in Gorontalo regency and very near with Limboto district. Telaga Biru is found 4 endemic village of DHF Incidence.²

Geographic information systems (GIS) and remote sensing are reliable tools in surveillance of prevention and eradication of infectious diseases. Geographic information system is also highly relevant to use in the investigation of outbreaks and rapid actions to overcome, because of the geographic information system to provide the exact location of the case, the communication of information quickly and mapping the epidemics dynamics of disease.³

To be aware the rotation of extraordinary events of DHF incidence, requires modeling of spatial epidemiology of dengue risk factor-based geographic information system (GIS). The result of spatial modeling in the form of vulnerability maps of districts to DHF, is expected to be used as a valuable input in the planning of prevention programs and eradication of dengue incidence as well as the result of effective and efficient decision making.⁴

Research Method

a. Type and research design

Type of study was observational used cross sectional study design supported by Geographic information System (GIS) to collected spatial information. Research design is a study of ecological with an approach spatial-temporal. The independent variables in this study is the weather are precipitation, temperature, humidity and wind speed while the dependent variable in this study was the incidence of DHF. Population in this study were all cases in the

administrative area of Limboto District with the case of DHF during the period of 2012-2015.

b. Study Area

Limboto district is one of 19 districts on Gorontalo regency. This districts consist of 12 villages. Total area Limboto district are 130.5 km² or equal to 5.91% total area of Gorontalo Regency. The Widest village are Polohungo and seen of earth surface morphology, most areas in the form are lowland region. Borderline of Limboto District, the east by district of Telaga Biru, the west by district of West Limboto, north borders with Nort Gorontalo Region and south by the district of Tabongo and Lake Limboto.

District of Telaga Biru is one of the 19 districts in Gorontalo regency. This district consists of 15 villages. Total area of Telaga Biru district are 107,40 km² or equal to 2,37 % total area of Gorontalo Regency. The Widest village are Ulapato B and seen of earth surface morphology, most areas in the form are plateau region. Borderline of Telaga Biru districts, the east by Bone Bolango regency, the west by district of Limboto, north borders with Gorontalo Utara regency and south by the district of Telaga Jaya.

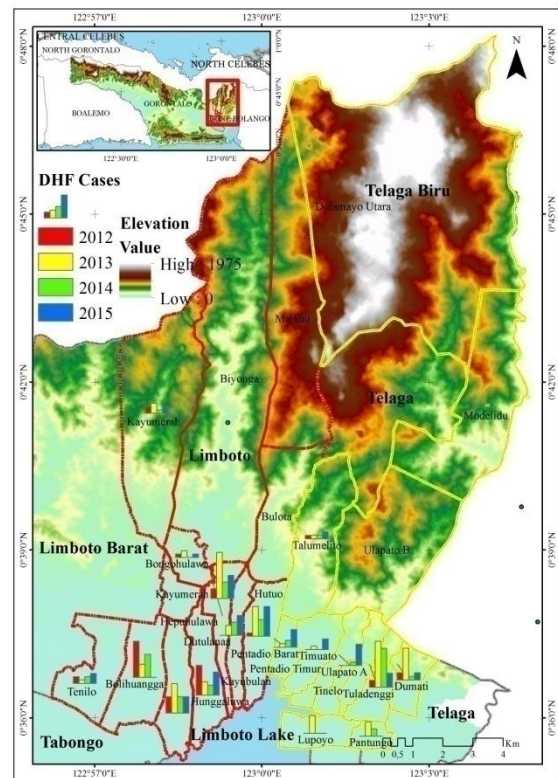

Figure 1. Study Area (Limboto and Telaga Biru District) and DHF Incidence 2012-2015

c. Data Collection

In order to achieve the objective of this study, several data are required to be incorporated in GIS environment such as DHF case data and precipitation data and climatology data. These data were gathered from various sources.

d. Data Analysis

1. **Univariate Analysis**
Univariate analysis is statistically used to know the frequency distribution of each variable in this research that is weather factor (precipitation, temperature, humidity and wind speed) and DHF incidence in Limboto and Telaga Biru District.
2. **Graph/Time-Trend Analysis**
Graph/time-trend analysis is performed to show the pattern of graphic relationship between weather variables (precipitation, temperature, humidity and wind speed) on DHF incidence.
3. **Bivariate Analysis**
Bivariate analysis was performed to see statistically correlation between weather variables with DHF incidence. Before performing bivariate data analysis it is necessary to test the data normality. If the data is normally distributed, the test is Pearson Moment correlation test, and if the data is not normally distributed then the test to be used is Spearman-Rho correlation test. The correlation test was performed by linking the occurrence of DHF with weather variables (precipitation, temperature, humidity and wind speed) in the same month (lag0) up to two previous months (lag2).
According Dahlan (2010) Interpretation of correlation power between two variables based on their correlation coefficient value can be divided into five statistically.⁵
 - r = 0-0.2 extremely weak
 - r = >0.2 – 0.4 weak
 - r = >0.4 – 0.6 medium
 - r = >0.6 – 0.8 strong
 - r = >0.8 extremely strong
4. **Multivariate Analysis**
Multivariate analysis was conducted to show the influence on weather variables (precipitation, temperature, humidity and wind speed) with DHF incidence. This analysis is by using *Poisson Regression*. If there is an assumption violation, the analysis proceeds with a *Negative Binomial*

Regression. This research thus getting the best regression model.
The Poisson Regression Model can generally be written as follows:

$$\ln(Y) = \beta_0 + \beta_1 X_{i1} + \beta_2 X_{i2} + \dots + \beta_k X_{ik}$$

$$Y = \exp(\beta_0 + \beta_1 X_{i1} + \beta_2 X_{i2} + \dots + \beta_k X_{ik})$$

5. **Spatial Analysis**
Data is presented in thematic maps illustrating the distribution of cases in 12 and 15 villages in the district administrative Limboto and Telaga Biru District. Meanwhile, to create thematic maps weather variable interpolation advance. Interpolation is executed by using weather variable data in the form of point from weather station, so it becomes data area (surface) such as precipitation, temperature, humidity and wind speed. Then to show the pattern of the relationship on independent variables and the dependent variable spatially, overlaying thematic maps the distribution of DHF cases with weather variables.

Result

Precipitation and climatological data collected through the Central River Region of Celebes II. In the study area there were 21 precipitation gauge stations distributed inside or outside the study area, but in this study only affected 2 precipitation gauge stations due and 1 climatology stations. The data collected as the variables studied in this study are precipitation, temperature, humidity, and wind speed for 4 years (2012-2015).

1. **Univariate Analysis**
Univariate analysis data shows frequency distribution of environment variables and DHF cases in Limboto and Telaga Biru district in 2012-2015. The characteristics of each research variable descriptively presented in the table.

Table 1. Frequency Distribution of Environment Variables

Area	Variables	X	Var	SD	Max	Min
Limboto	Precipitation	141.179	7800.817	88.322	333	1.7
Telaga Biru		133.199	6063.467	77.868	303.64	3.99
Limboto	Temperature	27.107	0.181	0.425	28.19	26.2
Telaga Biru		27.362	1.431	77.868	29.42	18.93
Limboto	Humidity	83.211	17.306	4.160	91.26	67.39
Telaga Biru		87.342	39.911	6.317	95.77	64.16
Limboto	Wind speed	108.714	2298.945	47.947	246.18	49.18
Telaga Biru		48.502	168.0045	6.317	90.55	28.86
Limboto	DHF Incidence	3.229	22.818	4.777	26	0
Telaga Biru		2.929	21.802	4.656	24	0

Monthly precipitation in Limboto District during 2012-2015 shows a maximum value of 333 mm occurred in April 2013. Minimum value of 1.7 mm occurred in September 2014. The monthly temperature in the period 2012-2015 is not too varied. The maximum value of 28.19°C occurred in December 2015, and the minimum value of 26.20°C occurred in

July 2013. Humidity during the period 2012-2015 shows the maximum value of 91.26% occurred in September 2013 and the minimum value of 67.39 % in December 2015. Wind speed for the 2012-2015 period shows a maximum value of 246.18 km / day occurred in August 2015 and a minimum value of 49.18 km / day in May 2013 (Pakaya, 2017)⁶.

Monthly precipitation in Telaga Biru district during 2012-2015 shows a maximum value of 303.64 mm occurred in May 2013. Minimum value of 3.99 mm occurred in September 2014. The monthly temperature in the period 2012-2015 is shows maximum value of 29.42°C occurred in April 2013, and the minimum value of 18.93.°C occurred in October 2012. Humidity during the period 2012-2015 shows the maximum value of 95.77% occurred in August 2013 and the minimum value of 64.16 % in November 2012. Wind speed for the 2012-2015 period shows a maximum value of 90.55 km / day occurred in November 2012 and a minimum value of 28.86 km / day in September 2013.

The test results show the monthly precipitation and monthly temperature variables have $p > \alpha$ (0.05), meaning H_0 is accepted, so that they do not have normal curve or normal data variables and the humidity, wind speed and DHF cases are non-normal distribution (Table 2).

1. Bivariat Analysis

Table 2. Data Normality Test Results

Variabel	Shapiro-Wilk	Normality
Monthly Precipitation	0.14365	Normal
Monthly Temperature	0.43425	Normal
Monthly Humidity	0.00002	Non-Normal
Monthly Wind speed	0.00107	Non-Normal
Monthly DHF cases	0.00000	Non-Normal

Table 3. Correlation Analysis of Environmental Variables against Dengue Event

Lag	Monthly Precipitation		Monthly Temperature		Monthly Humidity		Monthly Wind Speed	
	p-value	r	p-value	r	p-value	r	p-value	r
0	0.0820	0.2536	0.9982	-0.0003	0.9205	0.0148	0.9854	-0.0027
1	0.9964	0.0007	0.8861	-0.0212	0.846	-0.1948	0.9994	0.0001
2	0.2269	0.1776	0.8290	0.0320	0.0132	-0.3554	0.8693	0.0244

Table 3 shows only the humidity in the previous two months (lag2) P = 0.01 which has a significant

relationship but the correlation is negative (Pakaya 2017).

Table 4. Correlation Analysis of Weather Variables against Dengue Incidence in Telaga Biru District

Lag	Monthly Precipitation		Monthly Temperature		Monthly Humidity		Monthly Wind Speed	
	p-value	r	p-value	r	p-value	r	p-value	r
0	0.0609	0.075	0.319	0.147	0.515	0.09	0.01	0.343
1	0.866	-0.02	0.08	0.254	0.425	0.117	0.132	0.221
2	0.09	0.242	0.122	0.226	0.988	0.002	0.74	0.048

Table 4 shows correlation Analysis of weather variables against DHF Incidence only the wind speed

in the same months (lag0) P = 0.01 which has a significant relationship and have positive correlation (r=0.343).

2. Time-Trend Graph Analysis

Time-series graph of monthly precipitation with DHF cases shows tend to be directly proportional that the

case of DHF incidence increase when precipitation increases and vice versa, except the month with high

precipitation that is > 250 mm (May 2013), tends to decrease the number of DHF cases (Figure 2). On the graph of monthly temperature and DHF incidence show a tendency to be proportional to the case of DHF increases when the monthly temperature increases and vice versa (Figure 2). On the graph of monthly

humidity and DHF incidence each year tends to be directly proportional to 2012-2014 and is inversely proportional to 2015 (Figure 2). Graph of wind speed and DHF incidence show the incidence of DHF mostly occurs when wind speeds range from 35-100 km/day (figure 2)⁶.

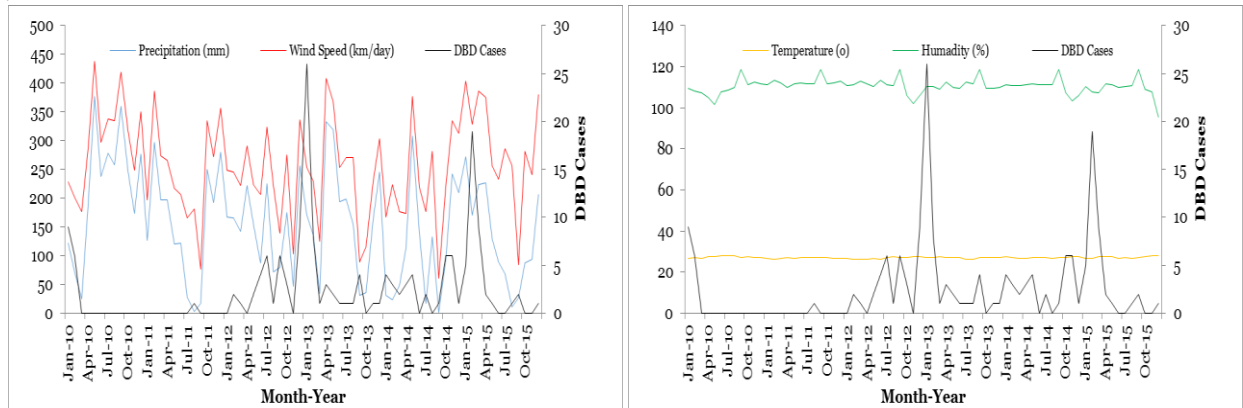

Figure 2. Time-Trend Graph Weather against DHF Incidence in Limboto District

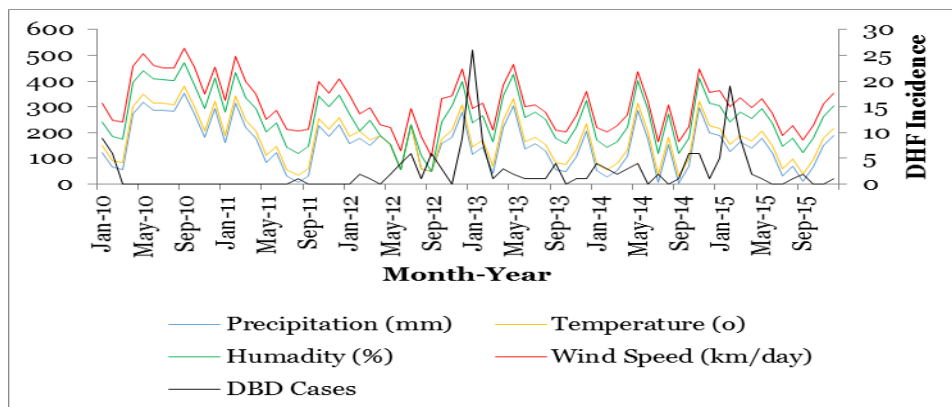

Figure 3. Time-Trend Graph Weather Variables against DHF Incidence in Telaga Biru District

Time-series graph of monthly precipitation with DHF Incidence shows that the cases of DHF incidence increase when precipitation increases (January 2013), except the month with high precipitation that is $\pm >300$ mm (January 2012, May 2012 and May 2013), tends to decrease the number of DHF incidence (Figure 3). On the graph of monthly temperature and DHF incidence show a tendency to be proportional to the DHF incidence increases when the monthly temperature increases and vice versa (Figure 3). On the graph of monthly humidity and DHF incidence the relationship between humidity and DHF incidence each month tends to be inversely proportional to the incidence of DHF decreases when the humidity increases (Figure 3). On the graph relationship between wind speed and incidence of DHF each month tend to be inversely proportional to incidence of DHF

increases when wind speed decreases in January 2015 (figure 3).

3. Spatial Analysis

The result of overlay of thematic annual precipitation and annual DHF incidence map do not all have a directly proportional relationship spatially. In general in 2012-2015, region in high areas and high precipitation, but DHF incidence is very small or no DHF cases. This explains that the elevation factor of the region is quite influential on the case of DHF in Limboto and Telaga Biru district. Limboto District is endemic area due to every year contained DHF cases, although high annual precipitation in the north and low in the south areas ⁶.

On thematic maps shows correlation on precipitation against DHF Incidence. In the years

2012-2015 shows precipitation increases in Limboto and Telaga Biru area and following increases of DHF Incidence. However, on thematic maps shows that the village which high ground in Limboto district is Bionga and Telaga Biru district is dulamayo village have high precipitation but no DHF incidence.

The result of the overlay between the annual temperature and annual DHF incidence map in Limboto and Telaga Biru district showed there is a direct relationship between temperature and the incidence of DHF the region having temperature 26°C-27,5° C which it is the optimum temperature for growth and physiological processes of mosquitos.

On the overlay map that the average of Humidity in Limboto and Telaga Biru districts in 2012 to 2015 is below 83% or ranged between 65-83% so this is very optimal as for mosquito breeding.

On the map of annual wind speed in Limboto district in the last four years from 2012-2015 it is seen that the central and eastern regions of Limboto district have high wind speeds but there's no DHF incidence. In Telaga Biru district showed wind speed seen low in the eastern area and following by highly DHF incidence. The wind affects the flying distance of mosquitoes and the pattern of the spread of mosquitoes. Seen on the overlay map of wind speed and DHF cases, the high wind speed fluctuation pattern that can be seen from color degradation on the map, will be followed by the high DHF case in the region and vice versa (figure 4).

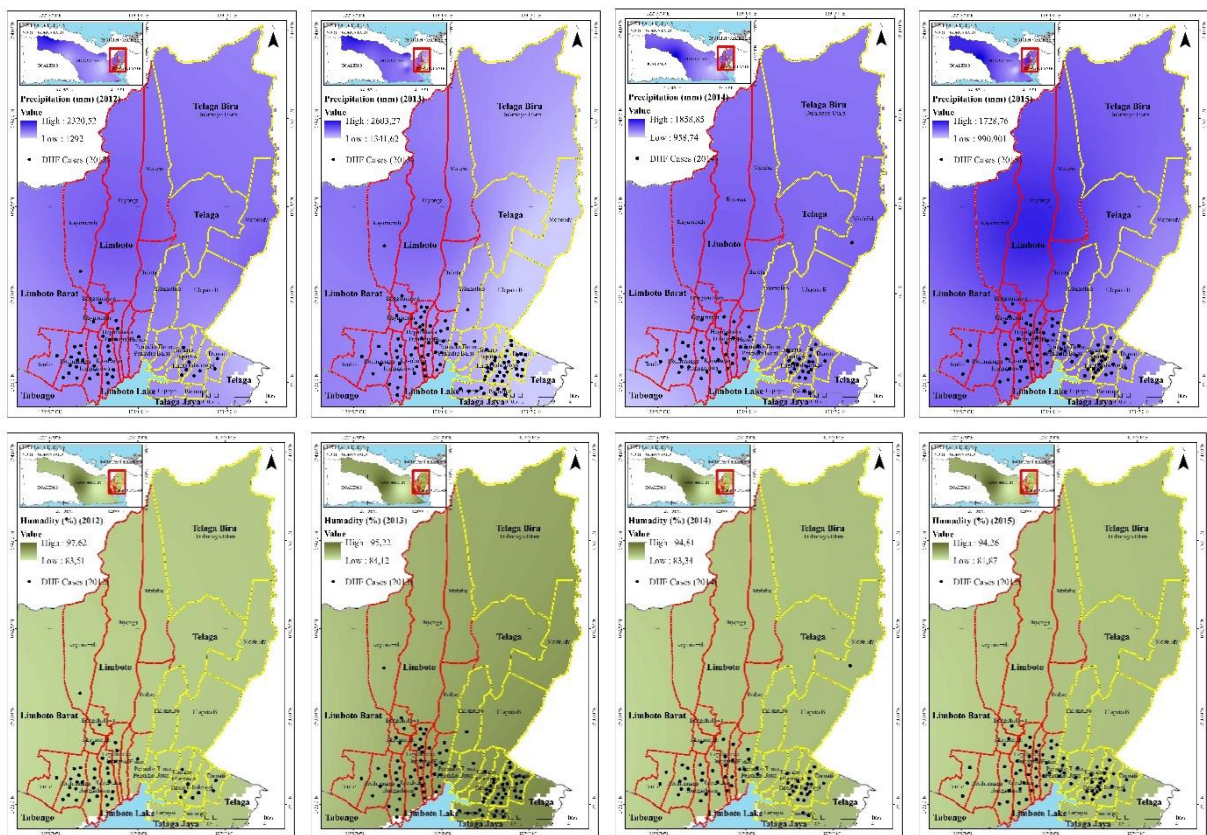

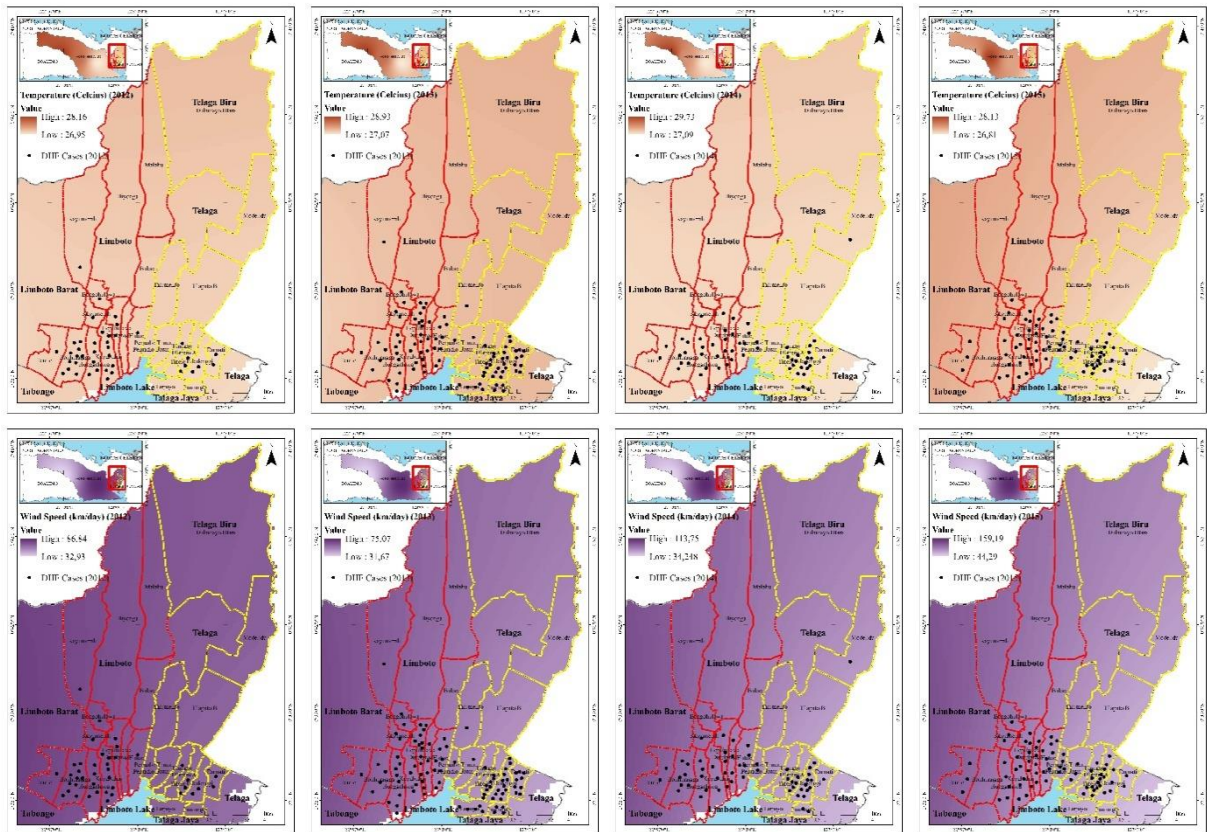

Figure 4. Map Of Distribution Precipitation, Climatology and DBD Incidence: Precipitation; Humidity; Temperature; and Wind Speed; (Top to Down)

4. Multivariate Analysis

a. Poisson regression analysis

Variables used into the Poisson Regression analysis described in Table 5. The Poisson Regression Model can generally be written as follows:

$$\ln(Y) = \beta_0 + \beta_1 X_{i1} + \beta_2 X_{i2} + \dots + \beta_k X_{ik} \quad (1)$$

$$Y = \exp(\beta_0 + \beta_1 X_{i1} + \beta_2 X_{i2} + \dots + \beta_k X_{ik}) \quad (2)$$

From the results of Table 6, the Poisson Regression Model is generated as follows:

$$\ln(Y) = 24.597 + 0.023X_1 + 0.565X_5 - 0.680X_6 - 0.235X_{10} - 0.007X_{13}$$

Table 5. Variable Poisson Regression Analysis

Variable	Information
Y	monthly DHF
X ₁	monthly DHF cases in the previous month (lag1)
X ₂	monthly precipitation in the same month (lag0)
X ₃	monthly precipitation in the previous month (lag1)
X ₄	monthly precipitation in the previous two months (lag2)
X ₅	monthly temperature in the same month (lag0)
X ₆	monthly temperature in the previous month (lag1)
X ₇	monthly temperature in the previous two months (lag2)
X ₈	monthly humidity in the same month (Lag0)
X ₉	monthly humidity in the previous month lag1)
X ₁₀	monthly humidity in the previous two months (lag2)
X ₁₁	monthly wind speed in the same month (lag0)
X ₁₂	monthly wind speed in the previous month (lag1)
X ₁₃	monthly wind speed in the previous two months (lag2)

Table 6. Result of Regression Poisson Analysis in Limboto District

<i>Parameter</i>	<i>Estimate</i>	<i>Standart Error</i>	<i>P Value</i>	<i>Information</i>
β_0	24.597	8.578	0,004	constants
β_1	0.023	0.011	0,047	DHF incidence in the previous month (<i>lag1</i>)
β_5	0.565	0.260	0,030	monthly temperature in the same month (<i>lag0</i>)
β_6	-0.680	0.267	0,011	monthly temperature in the previous month (<i>lag1</i>)
β_{10}	-0.235	0.312	0,000	monthly humidity in the previous two months (<i>lag2</i>)
β_{13}	-0.007	0.002	0,002	wind speed in the previous two months (<i>lag2</i>)
L_1	-110.950			
L_0	-164.95			

Result of *Regression Poisson Analysis* shows that weather variables which have a correlation against DHF incidence are DHF incidence in the previous month (*lag1*) monthly temperature in the same month (*lag0*), monthly temperature in the previous month (*lag1*), monthly humidity in the previous two months (*lag2*), and wind speed in the previous two months (*lag2*) (Table 6).

Table 7. Result of Regression Poisson Analysis in Telaga Biru District

<i>Parameter</i>	<i>Estimate</i>	<i>Standart Error</i>	<i>P Value</i>	<i>Information</i>
β_0	-9.132327	4.205927	0.03	constants
β_1	0.050892	0.013003	0.000	DHF cases in in the previous month (<i>lag1</i>)
β_{11}	0.032375	0.0154962	0.037	monthly wind speed in the same month (<i>lag0</i>)
β_{13}	-0.034657	0.0136919	0.030	monthly wind speed in the previous two months (<i>lag2</i>)
L_1	-0.110.86			
L_0	-0.99.107			

Result of *Regression Poisson Analysis* shows that weather variables which have a correlation against DHF incidence are DHF incidence in the previous month (*lag1*), monthly wind speed in the same month (*lag0*) and monthly wind speed in the previous two months (*lag2*) (Table 7).

Discussion

Based on the map of the distribution of DHF incidence from 2012 to 2015, in general the movement of dengue cases tend to attack the area close to Lake Limboto. In the Year 2012-2015 most cases of DHF are found in Limboto and Telaga Bru district.

The result of correlation statistic test between monthly precipitation and monthly DHF incidence have positive correlation coefficient but has no significant correlation. Precipitation can affect the life of mosquitoes in 2 ways, namely: causing the rise of air relative humidity and add a place of longing. Every 1 mm precipitation adds a density of 1 mosquito, but if the weekly precipitation is 140 mm, the larvae will drift and die.⁷ This is in line with research conducted by Iriani (2012) on the assessment of the relationship between monthly precipitation rates and dengue cases through Spearman correlation test ie there is a correlation between precipitation and increasing the number of dengue cases treated.⁸ The correlation began one month before the peak precipitation ($r = 0.332$, $p = 0.001$), increased during peak precipitation ($r = 0.353$, $p = 0.000$), and weakened one month afterwards ($r = 0.262$; $p = 0.008$).

While for yearly graph analysis shows that the relationship of monthly precipitation and monthly DHF cases tend to be unidirectional. The highest annual precipitation is in 2010 and 2013 where in that year DHF cases are also very high, this proves that there is a relationship of annual precipitation with annual DHF cases. If observed on the overlay map between thematic annual precipitation maps and thematic maps of monthly DHF cases per county, where in 2012-2015 high annual precipitation occurs in some areas of Limboto and Telaga Biru district located adjacent to Lake Limboto. The result of overlay of thematic annual precipitation maps and the annual DHF cases do not all have a directly proportional relationship spatially. In general in 2012-2015, county in high areas have high annual precipitation, but the annual DHF cases are very small or no DHF cases at all. This explains that the altitude of the place is enough to affect the case of DHF in Limboto District.

The results of research conducted by Chen et al (2012) using Correlation Person Product Moments obtained results that extreme precipitation associated with the case of 8 infectious diseases in Taiwan during the period 2004-2008, including dengue fever disease. Precipitation is significantly associated with dengue fever with P value of test (0.0212).⁹ The results of research by Thai et al (2010), with time series analysis of climate variables in all districts in Vietnam with DHF cases, it was found that climatic variables were significantly related to DHF cases over the last 2-3 years.¹⁰ In a study conducted by González et al (2011) using multiple regression analysis, the rainy season, winter and dry season had an effect on increasing the DHF cases ($P = 0.079$, $P = 0.008$; $P = 0.015$) in Mexico.¹¹ Temperature is one of the environmental factors that

affect the breeding of *Aedes Aegypti* mosquito larvae and also affect the development of viruses in the mosquito body.¹² In this study there is a relationship between monthly temperature with the monthly DHF cases statistically and will be stronger when associated with fluctuations in monthly temperature in the previous 2 months (lag2) is associated with the monthly DHF cases. In the correlation analysis in this study there was no significant relationship between temperature with the DHF Cases statistically $P = 0.9982$.

This research is in line with Dini et al. research, which states there is no relation between temperature and DHF case in Serang Regency in 2007-2008.¹³ However, this study is not in line with the results of research conducted by Thai, with the result that the climate variable (temperature) is significantly related to DHF cases over the past 2-3 years¹⁰. This could be due to differences in total duration of data taken in conducting research and difference in conditions where do research.

Increased temperature due to climate change causes the incubation period of mosquitoes is getting shorter. The impact of mosquitoes will multiply faster. Increasing the population of mosquito vectors will increase the chances of disease agents with mosquito vectors (such as dengue hemorrhagic fever, malaria, filariasis, chikungunya) to infect humans.¹⁴

The results of research by Costa et al (2010) on the impact of temperature and humidity variation on reproduction activities and survival of *Aedes aegypti* mosquitoes, the results obtained that at 35°C and relative humidity of 60% will decrease the level of mosquito oviposition (average $54,53 \pm 4.81$ eggs), whereas at 25°C and relative humidity 80%, the potential for mosquito oviposition rate (mean 99.08 ± 3.56 eggs).¹⁵

In this study the fluctuation of monthly humidity in the same month (lag0) showed positive correlation coefficient value but statistically in significant value was associated with monthly DHF case (limboto district). However, different things were shown in the monthly humidity of the previous 2 months (lag2) that the negative correlation coefficient value was negative ($r = -0.355$) but had significant value ($p = 0.01$) associated with monthly DHF cases. According Dini (2010), humidity does not directly affect the case rate of DHF, but it affects the age of *A. Aegypti* mosquito which is the vector of dengue transmitter. Mosquito breathing using a tracheal pipe with an aperture is called a spiracles.¹² Spiracles that are open without a regulatory mechanism at low humidity will cause evaporation of water from inside the mosquito body so that the mosquito's body fluid will come out. In addition, the need for high humidity causes mosquitoes to find a humid and wet place outside the home as a place to rest during the day.¹⁶

In the time-series graph the monthly humidity relationship and monthly DHF cases tend to be reversed is the monthly DHF cases increase

when the monthly humidity decreases. The same thing is also seen on the overlay map between annual humidity and the annual DHF cases that there is a relationship inversely spatially over the last four years 2012-2015.

According to Sukamto (2007), *Aedes aegypti* mosquitoes will lay their eggs at an air temperature of about 25^o-30^oC. Eggs laid in water will hatch at 75 hours or 3 to 4, but at temperatures less than 17^oC can only last for 1 hour.¹⁷ According to Gubler (2010), air humidity affects the age of mosquitoes. At temperature 20^oC relative humidity 27% age 31 day female mosquitoes and age 35 days male mosquito, relative humidity 55% age 88 day female mosquitoes and male mosquito 50 days.¹⁸ At relative humidity less than 60% of the age of the mosquito will be short, it cannot be a vector, because there is not enough time to transfer the virus from the stomach to the salivary glands. Therefore, more than 60% of the air humidity makes *Aedes aegypti* mosquitoes long and potential for breeding of *Aedes aegypti* mosquitoes.

Monthly wind speed has a strength of correlation value is weak with a positive direction when associated with previous months (*lag*) and there is significant relationship with the monthly DHF cases (Telaga Biru district).

This is no in line with research Wiragoya (2013) that the statistical results between wind speed with the case of DHF shows the value of $r = 0.057$ and $p = 0.632$ which means that wind speed has a very weak relationship strength and there is no significant relationship between wind speed and the case of DHF.¹⁴

On the graph between monthly wind speed and monthly DHF cases each year shows a direct relationship for the year 2012-2015. Seen on the map of annual wind speed overlaid with annual DHF cases, the pattern of high annual wind speed fluctuations that can be seen from the degradation of color on the map, it will be followed by the high annual DHF cases in the region and vice versa.

In Lu et al (2009) it is explained that the wind tends to inhibit flying as well as affect the oviposition of mosquitoes or the placement of eggs in suitable positions and habitats. Increased wind speeds generally cause a decrease in the ability of mosquitoes flying with wind speeds of 1-4 m/s can inhibit the flight of mosquitoes.¹⁹

Conclusion

This paper has offered some useful information related to the DHF incidence. Analysis of the environmental factors such as precipitation, temperature, humidity and wind speed with the DHF incidence has revealed that DHF generally occurred when average temperature rose above normal. The result of overlay of thematic annual precipitation and annual DHF cases map do not all have a directly proportional relationship spatially.

In the time-series graph the monthly humidity relationship and monthly DHF cases tend to be reversed is the monthly DHF cases increase when the monthly humidity decreases.

In *Regression Poisson Analysis* shows that weather variables which have a correlation against DHF incidence in Limboro district are DHF incidence in the previous month (*lag1*) monthly temperature in the same month (*lag0*), monthly temperature in the previous month (*lag1*), monthly humidity in the previous two months (*lag2*), and wind speed in the previous two months (*lag2*). While, the result of Regression Poisson analysis in Telaga Biru shows

Acknowledgement

This study was carried out within a wider research program on remote sensing and epidemiology, funded by Public Health Faculty, Universitas Gorontalo.

References

1. Philippe Dussart et. Al (2006) Reemergence of Dengue Virus Type 4, French Antilles and French Guiana, 2004-2005, Emerging Infectious Diseases. www.cdc.gov/eid Vol. 12. No.11
2. Health Department Office of Kabupaten Gorontalo (2015). Profil Kesehatan Kab. Gorontalo Tahun 2015.
3. WHO. (2010) GIS and Public Health Mapping (Online). WHO. Available; http://www.who.int/helath_mapping/en/ (acssed 20 mei 2017)
4. Hasyim Hamzah, (2009) Analisis Spasial Demam Berdarah Dengue Di Provinsi Sumatra Selatan, Jurnal Pembangunan Manusia, Vol. 9 No. 3
5. Dahlan, MS. Mendiagnosis dan menata laksana 13 penyakit statistik. Jakarta:Sagung Seto;2010.
6. Pakaya Ririn. (2017). Spatial Analysis And Environmental Factors Associated Against Case Of Dengue Hemorrhagic Fever (Dhf) In Limboto District, Gorontalo. Internasional Seminar of Occupational and medical. Semarang
7. Suroso T, Hadinegoro SR, Wuryadi S, Sumanjuntak G, Umar AI, dan Pitoyo PD. Penyakit demam berdarah dengue dan demam berdarah dengue. Jakarta: WHO dan Depkes. RI;2003.
8. Iriani Y. Hubungan Antara Curah Hujan dan Peningkatan Kasus DBD Anak di Kota Palembang. *Jurnal Sari Pediatri*, Vol. 13 No. 6 Palembang.2012
9. Chen MJ, Lin CY, Wu YT, Wu PC, Lung SC, and Su GJ. Effects of extreme precipitation to the distribution of infectious diseases in Taiwan, 1994–2008. *Journal PLOS One*.2012;7(6).
10. Thai KT, Cazelles B, Van Nguyen N, Vo LT, Boni MF, Farrar J, Simmons CP, Van Doorn, HR, and De Vries, PJ. Dengue dynamics in Binh

- Thuan Province, Southern Vietnam: periodicity, synchronicity and climate variability. *Plos Neglected Tropical Diseases* (open access).2010;4(7).
11. González FJC, Lain R, Lake, IR, and Bentham G. Climate variability and dengue fever in warm and humid Mexico. *The American Journal of Tropical Medicine and Hygiene*.2011;84(5):757–763.
 12. Ridha MR, Rahayu N, Rosvita NA, dan Setyaningtyas DE. Hubungan kondisi lingkungan dan kontainer dengan keberadaan jentik nyamuk *Aedes Aegypti* di daerah endemis demam berdarah dengue di Kota Banjarbaru. *Jurnal Buski*.2013;4(3):133 – 137.
 13. Dini, A. M. & Wulandari, R. A. Faktor Iklim dan Angka Insiden Demam Berdarah Dengue di Kabupaten Serang. *Makara Kesehatan Depok. Universitas Indonesia*. 2010;14(1, 31-38).
 14. Wirayoga MA. Hubungan kejadian demam berdarah dengue dengan Iklim di Kota Semarang tahun 2006-2011. *Unnes Journal of Public Health*.2013;2(4).
 15. Costa EAPA, Mendonça, Santos EMMS, Correia JC and Albuquerque CMR. Impact of small variations in temperature and humidity on the reproductive activity and survival of *Aedes aegypti* (Diptera, Culicidae). *Journal Revista Brasileira de Entomologia*.2010; 54(3).
 16. Susanna D, dan Sembiring, TUJ. *Entomologi kesehatan (Artropoda pengganggu kesehatan dan parasit yang dikandungnya)*. 1st ed. Jakarta:UI Press;2011.
 17. Sukamto. *Studi karakteristik wilayah dengan kejadian DBD di Kecamatan Cilacap Selatan Kabupaten Cilacap [Thesis]*. Semarang: Universitas Diponegoro;2007.
 18. Gubler DJ. The Global threat of emergent /re-emergent vector-borne disease. In Atkinson, P.W. Ed. *Vector Biology, Ecology and control*. New York: Springer+Business Media;2010
 19. Lu L, Lin H, Tian L, Yang, W, Sun J and Liu, Q. Time series analysis of dengue fever and weather in Guangzhou, China. *BMC Public Health*.2009;9:395.

ANALYSIS THE DIFFERENCES INCIDENCE OF STUNTING AGE 24 -59 MONTHS IN MOUNTAINS AREA AND COASTAL MARINE IN GORONTALO REGENCY

*Yeni Paramata, Rahmawati, Zul Adhayani Arda
Faculty of Public Health, Gorontalo University*

ABSTRACT

Background. *Stunting is a child's body that can not grow well, or hampered, so they are short on appeal to the height they should achieve at that age. According to Riskesdas 2013 data, the stunting problem is quite high at 37.2%, which means an increase compared to 2010 (35.6%) and 2007 (36.8%).*

Objective. *To analyze the difference of incidence of stunting aged 24-59 months in the mountains area and coastal marine of Gorontalo regency.*

Method. *The type of research used in this study is observational analytic with Cross Sectional Study design. The number of samples were 233 children aged 24-59 months who were selected proportional random sampling.*

Result. *proportion of children under five suffered Stunting as many as 139 people (59.7%). Variables that have significant differences with the occurrence of stunting between the mountains and coastal areas ie; (p 0.001), intake of vitamin A (p 0.001), intake of zinc (p 0,000) BBL (p 0,000), history of infectious diseases (p 0,000), history of exclusive breastfeeding (p 0,000) and age of first breastfeeding (p 0.004). There was no significant difference between iron intake (Fe) (p 0.148), height of father (p 0.188), maternal height (p 0.088), immunization history (p 1,000), history of pregnancy diseases (p 0.886) between the mountains and the coast. The dominant factor that has the highest difference in toddlers between mountains and coastal marine areas is Low Birth Weight.*

Conclusion. *Weight of low birth weight infants 10,081 with the occurrence of stunting between mountainous areas and coastal marine area of Gorontalo regency.*

Keywords: *Stunting, mountains area, coastal marine area*

Influence of Leader's Behaviour, Motivation, and Work Satisfaction Toward Organizational Citizenship Behaviour (OCB) of Nurses

Wirda Y. Dulahu¹, Dzohra Puasa²
Nursing study Program Gorontalo State University
Correspondence Email: wirda@ung.ac.id

A current phenomenon encountered by the hospital in providing optimum service is the relationship between human resources of nurses and organization. One of influencing factors is Organizational Citizenship behavior (OCB). It is behaviour which is not includes in employee's formal duty obligation, Yet it promotes the work of organizational effectifely and give impact to nursing performance. Problem statement of this research is wether or not there is influence of leader's behaviour, motivation, and work satisfaction toward OCB.

This research aims to investigate leader's behaviour, motivation, and work satisfaction factors which influence OCB of nurses in intensive care rooms (PICU, ICCU, ICU) regional hospital of Prof. Dr. H. Aloe Saboe of Gorontalo City. This is a descriptive analytical research in which its samples are determined by total sampling with criteria of samples exclusion of the person is not head of room and not on duty. Data are collected by questionnaire.

Research finding reveal that nurses with high OCB are 43 people (87,76%) and nurses with medium OCB are 6 people (12,24%). Leader's behaviour, work satisfaction are significantly influence OCB, however the most significant one is motivation with p-value of 0,000.

Conclusion of the research reveals that motivation, Leader's Behaviour, and work satisfactions is significant factors which influences OCB . So, Expected to the institution to improve Motivation, Leader's Behaviour, and work satisfactions toward OCB.

Keywords : Organizational citizenship behaviour, nurses

IDENTIFICATION OF BACTERI RACING AND NUTRITION CONTENT IN PINDANG TUNA FISH FOR SALE IN TRADITIONAL MARKET CIAWI DISTRICT TASIKMALAYA

Dian Saraswati¹⁾ and Ai Sri Kosnayani¹⁾

¹⁾ Faculty of Health Science, Siliwangi University

ABSTRACT

The main obstacle in the marketing of fresh tuna is a short durability due to bacterial *Pseudomonas*, *E. coli*, *Salmonella*, *Klebsiella*, *Enterobacter*, *Proteus* and *Yersinia* decomposition. Diseases caused when the bacteria enter the human body such as fever, abdominal pain and diarrhea. Preparation of tuna fish is one of the food processing efforts in order to preserve, increase digestibility, and flavor enhancer, but food processing can also affect nutritional value. The purpose of this research is to know the existence of bacteria and macro nutrient content pindang tuna fish that sold in Ciawi traditional market. The research used descriptive method through laboratory test of bacteria test, biochemical test (motile test, Methyl-Red, Voges-Proskauer, TSIA, KIA, simon citrate and carbohydrate fermentation test) for six samples and three replications. The results showed that in pindang tuna bacteria *Pseudomonas aureginosa*, *E. coli*, *Salmonella tyhpi* was negative. Analysis of macro nutrients found carbohydrate and fat content in tuna pindang higher but the protein content is lower than fresh tuna.

Keywords: pindang tuna, bacteria, carbohydrat, protein, lipid

PRACTICAL STATEMENT

Seeing the results of bacterial identification in boiled tuna negative, then the way cob boiled fish production in Ciawi market can be developed in terms of hygiene health. Should be examined about the causes decreased levels of protein and fat content sizeable increase. Do sharing between merchants boiled tuna to improve the quality of boiled tuna particularly the levels of nutrients, because each trader has its own advantages.

INTRODUCTION

Tuna is a food source of protein that is consumed by Tasikmalaya community. As a source of tuna fish protein is a functional food that has significance for health because it contains long-chain saturated fatty acids (especially those classified as fatty acid $\omega 3$), vitamins and macro and micro molcul (Heruwati, ES 2002). Fresh tuna fish has a chemical composition consisting of 69.40% water, 1.5% fat, 25% protein, 2.25% ash, and 0.03% carbohydrate (Sanger, 2010). Bacteria and chemical changes in eye fish cause decay (Hiariey, S. and Lekahena, V. 2015) and compared with other foodstuffs, fish more quickly decompose (Mardiana, et al., 2014). Tuna cultivation by way of pemindangan is one alternative to maintain the quality of tuna fish.

In the area of West Java, including Tasikmalaya pindang outstanding common fish market is boiled fish boiled milk and tuna fish. Cob boiled fish is quite popular in the community because it is quite easy to do. How to make boiled fish is very simple, namely the process of added salt and then boiled. How to fish spoilage caused by boiling water from well water, cooking water is used repeatedly until fresh fish runs out or to wait for the next boiling process tuna left at room temperature.

Once the manufacturing process is completed followed by the marketing process, commonly marketed in traditional markets, if not sold in one day on selling to the next morning without adequate storage. This situation will affect the quality and safety of boiled tuna produced, in terms of quality mikrobiologisnya and bacterial content. Research results of Widiastuti, I. (2005) found that pindang fish with 40% salt content in 6 days storage of TPC value is still below the safe limit, if more than 6 days of boiled tuna fish is not feasible to be consumed.

The process of decay boiled tuna fish is caused by bacteria (*Pseudomonas*, *E coli*, *Salmonella*, *Klebsiella*, *Enterobacte*, *Proteus* and *Yersinia*), in the decay process occurs also the reduction of nutrients at the boiled tuna.

According to the Indonesian National Standard (DG Fisheries 1994/1995), quality standards are not boiled fish or negative bacteria. Macro-nutrients contained in boiled tuna can be classified into three groups: carbohydrates, protein and fat. Protein is a compound that can be damaged if heated too long and changes in pH.

In traditional markets Ciawi Tasikmalaya district there are 6 fish traders boiled cobs spread in the market, boiled tuna in the market is made by the vendors themselves, but the fish cob from the same manufacturer. From this background, we will make a study entitled Identification of Spoilage Bacteria and Nutritional content at the cob Pindang fish Circulating In Traditional Markets Ciawi Tasikmalaya Regency.

RESEARCH METHODS

Tools and Materials

The tool used in this research is autoclave, stirring rod, erlenmeyer, durham tube, incubator 37⁰C, electric stove, digital scales, bunsen burner, dispo1 ml, test tube, glass chemical, oven, volume measuring cup100 cm³ and 10 cm³, spatula, ose needle, vortex and petri dish (ϕ 100 mm).

The materials used in this research are six samples of pindang tuna fish, XLDA (Xylose Laktose Dextrose Agar), Ceta (Cetrimide Agar), MCA (Mac Conkey Agar), aquades, NA (Nutrient Agar) for Semisolid, Triple Sugar Iron Agar TSIA), Simmon Citrate Agar (SCA), NaCl (Sodium Chloride), lactose, sucrose, glucose, Methyl Red - Voges Proskauer (MR-VP), Bacto Peptone, Phenol Red, KIA (Iron Kigler agar), Selenite Cystine Broth (SCB), Lactose Broth (LB), KOH, alphanaphthol, alluminium foil and cotton.

Methods

The method used in this research is descriptive method. Laboratory tests include testing of bacteria, biochemical tests include tests motile, test methyl-Red, Voges-Proskauer test, test TSIA, KIA test, test and test simon citrate fermentation of carbohydrates (glucose, lactose, sucrose).

Specific medium used is XLDA for *Salmonella typhi*, CETA for *Pseudomonas aeruginosa* and MCA for *E coli*, a medium for biochemical tests are NA semisolid, TSIA, KIA, lactose, glucose, sucrose, Mr simon-Vp and citrate. The first medium used is a pre-enrichment medium is Lactose Broth. While the analysis of the content of the test using the macro nutrients carbohydrates, fats and proteins.

RESULTS

The results of the research in this study is divided into two, namely the results of microbiological and nutritional value of the macro, microbiology results can be seen in Table 1 below.

Table 1 Average Results Spoilage Bacteria Pindang Tuna Fish (in 3 replicates)

No	Bakteria	Result of number sample					
		1	2	3	4	5	6
1	<i>Escherichia coli</i>	-/negative	-/negative	-/negative	-/negative	-	-
						/negative	/negativ e
2	<i>Salmonella typhi</i>	-/negative	-/negative	-/negative	-/negative	-	-
						/negative	/negativ e
3	<i>Pseudomonas aeruginosa</i>	-/negative	-/negative	-/negative	-/negative	-	-
						/negative	/negativ e

From the results of laboratory tests on all samples negative bacterium *Escherichia coli*, *Salmonella typhi* and *Peudomonas aeruginosa*. This means that in six cob pindang fish samples there are three such spoilage bacteria.

In the visible image control (+) contained *Pseudomonas aeruginosa* bacteria growth while the samples no growth of bacteria *Pseudomonas aeruginosas*. When these bacteria were grown in specific media, these bacteria will produce a bluish pigment nonfluoresen, piosianin. Some strains of *Pseudomonas* are also able to produce a green fluorescent pigment, namely ploverdin. Can be seen in Figure 1 the control (+) greenish. While the sample no discoloration.

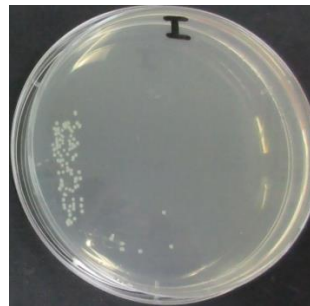

Sample

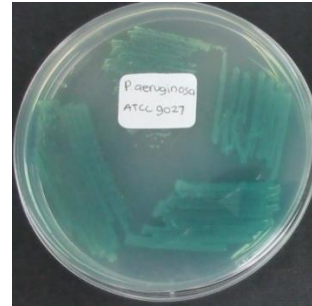

Control (+) *Pseudomonas*

aeruginosa

Figure 1. Growth in Media CETA, specific for *Pseudomonas aeruginosa* (Media Cetrimide Agar)

In the test IMViC (Indol- Methyl Red, Voges Proskauer, citrate and TSIA) *Pseudomonas aeruginosa*, microorganisms capable of using citric acid will then be removed from the culture medium, thereby causing an increase in pH and change the color of the medium from green to blue in the control (+), can be seen in Figure 2 below.



IMViC test results for sample



test results IMViC to control

(+)

Figure 2. Test IMViC *Pseudomonas aeruginosa*

To test *Escherichia coli* can be seen in Figure 3 using a specific media MCA (Media Mac Conkey Agar) can be seen in the control (+) colonies were, sorrel, methalik, smooth, keeping or slightly convex. While the sample no

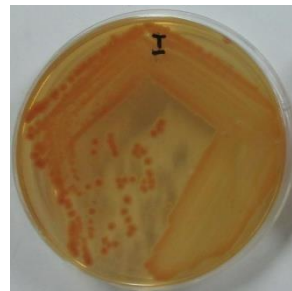

discoloration so negative Escherichia coli.



Sample

Control (+) *E. coli*

Figure 3. Growth in Media MCA, specific for *Escherichia coli*

In the test IMViC (Indol- Methyl Red, Vogues Proskauer, citrate and TSIA) *Escherichia coli*, microorganisms capable of using citric acid will then be removed from the culture medium, thereby causing an increase in pH and change the color of the medium from green to blue in the control (+).



IMViC test results for sample test results IMViC to control (+)

Figure 4. Test IMViC *Escherichia coli*

In the test using *Salmonella typhi* XLDA specific media (Media Xylose Lactose Dextrose Agar) bacterial colonies of pink with polka black spot in the middle can be seen in Figure 5.

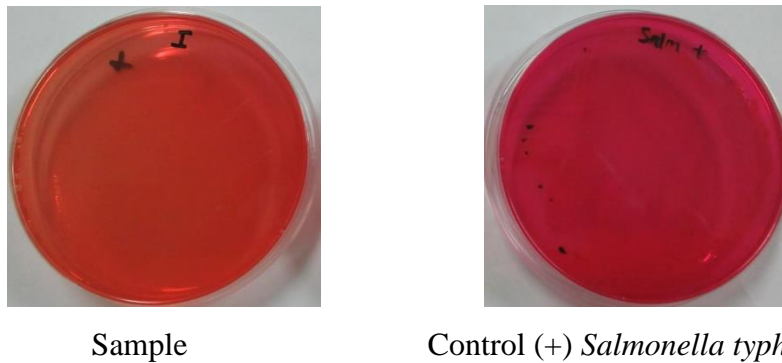

Figure 5. Growth in Media XLDA, for *Salmonella specific typhi*

In the test IMViC (Indol- Methyl Red, Vogues Proskauer, citrate and TSIA) *Salmonella typhi* can be seen in Figure 6. *Salmonella typhi* only positive there urease test. Urease enzyme will outline the urea into ammonia. Urease test showed a positive result if the color changes from yellow to red to purple. Urease test results negatively if the color changes from yellow to red to purple.



IMViC test results for sample test results IMViC to control (+)

Figure 6. Test IMViC *Salmonella typhi*

While the results of research into two is a macro nutrient content can be seen in table 2:

Table 2. Average Test Results Carbohydrate, Fat and Protein Content Analysis (g/100g) (in 3 replicates)

No. of Sample	Carbohydrate	Fat	Protein
1	7,93	14,80	7,53
2	6,96	6,68	3,60
3	3,84	4,76	1,93
4	13,16	1,58	6,97
5	6,84	2,20	3,84
6	9,12	2,18	7,19

From the results of the average carbohydrate content analysis above shows that the highest is number 4 while the lowest was number 3, of the average fat

content seen the highest levels of fat is the number 1 and the smallest is number 4 and of the average protein content seen the highest protein content analysis of protein content is number 6 and the lowest sample is number 3.

DISCUSSION RESEARCH

From the results of laboratory tests an average of 3 replicates to six samples were negative bacterium *Escherichia coli*, *Salmonella typhi* and *Peudomonas aeruginosa*. This is caused from the sale of a relatively clean environment as an example image 7 below:



Figure 7. Clean and healthy traders

The second thing is all pindang tuna fish traders produce 2 times a week so no fish boiled cobs were stored over 4 days. This is consistent with research of Widiastuti, I. (2005) states that the fish boiled with salt levels of 40% on a 6 day storage TPC value is still below safe limits. The results of this study also did not exceed the threshold of the Indonesian National Standard.

From the results of this study fish boiled cobs that are in the market Ciawi Tasikmalaya regency still secure consumed, next to the nutrient content of fish boiled cobs are as follows.

Table 3 Comparison of macro nutrient content of substances in fresh and pindang fish tuna (*Euthynnus affinis*)

No.	Macro Nutrient Content of Substance (g/100gram)			
	Nutrient	Fresh Tuna Fish	Pindang Tuna Fish	
1.	Carbohydrat	3,00	Sampel 1	7,93
			Sampel 2	6,96
			Sampel 3	3,84
			Sampel 4	13,16
			Sampel 5	6,84
			Sampel 6	9,12
2.	Protein	25	Sampel 1	7,53
			Sampel 2	3,60
			Sampel 3	1,93

			Sampel 4	6,97
			Sampel 5	3,84
			Sampel 6	7,19
			Sampel 1	14,80
			Sampel 2	6,68
3.	Fat	1,5	Sampel 3	4,76
			Sampel 4	1,58
			Sampel 5	2,20

Carbohydrate Analysis

Carbohydrates play an important role in determining the characteristics of food ingredients such as color and texture. The carbohydrate content is influenced by factors other nutrient content (Winarno 2008). Carbohydrates are widely present in vegetable materials, in the form of simple sugars, hexoses, pentoses, and high molecular weight carbohydrates such as starch, pectin, cellulose, and lignin. Animals convert vegetable carbohydrates into animal carbohydrates consisting mainly of glycogen. (Basari, ME., 2007). Carbohydrate content in the boiled tuna highest is 4 samples, closest to the carbohydrate content of fresh tuna is a sample 3. Change the value of the average carbohydrate levels occur due to changes in other nutritional components such as fats and proteins during the cooking process and storage.

However, increased levels of carbohydrate in the boiled tuna will not be a bad effect on health will only add calories produced.

Protein Analysis

The protein content in boiled tuna is much smaller than the fresh tuna fish and this is because the protein susceptible to denaturation caused by heating for too long and adding extra salt. Based on the results of interviews with traders boiled tuna, swordfish boiled cooking ranges between 6-7 hours. The protein content of boiled tuna decreased from fresh tuna fish. The increase in nitrogen content as a component of amino acids consistent with the loss of hydrogen due to the heating element. The longer heating can damage proteins (Maodan Tao 2008).

The heating causes the denatured protein structure, and coagulated into a simpler form. A simplified form of the protein makes the protein is unstable and easily changed on other conditions (Georgiev et al. 2008 and Swastawati et al. 2012). Denatured proteins will undergo coagulation when heated at a temperature of 50°C or more (Ghozali et al. 2004).

Salt is used in addition to adding flavor boiled tuna also for preservation, because one of the functions of salt is a preservative.

Fat Analysis

Fat is one of the macro nutrient required by the body but should be limited because it is associated with blood lipid levels (cholesterol and triglycerides) that trigger the onset of various diseases. Increased levels of fat boiled tuna fish can be

affected by factors intrinsic and extrinsic conditions of the raw materials used. Extrinsic factors caused by heat can react with enzymes in fish tissue makes fat levels increase in the rate of change (Stolyhwo and Sikorski 2005). Changes in the macro-nutrient content pindang tunny is not a reason not to consume boiled tuna, especially for people who are away from the coast because of the difficulty of getting fresh tuna. Consumption of boiled tuna can be used as an alternative to the benefits swordfish pretty much like:

- a. Lowering cholesterol, omega-3 content in tuna contribute to reduce the buildup of cholesterol in the body
- b. Overcoming anemia, a natural ingredient in the tuna is excellent for stimulating red blood cell formation. Anemia bias swordfish overcome by boiling, and eaten by consuming the broth all at once. If through a process pengorengan, some kind of protein in it is lost
- c. tackle dull, swordfish is also beneficial for skin problems in certain parts such as legs, knees, arms and elbows often feels rough and dull. The content of vitamin A and vitamin E in the tuna's useful to refine and brightened the skin.

CONCLUSIONS AND SUGGESTION

Conclusions

Sknot Boiled tuna sold in traditional market Ciawi not contain spoilage bacteria such as *Escherichia coli*, *Salmonella typhi* and *Pseudomonas aeruginosa*. Nutrient content of carbohydrates and fat boiled tuna sold in traditional market Ciawi increased while the protein content decreased compared with the nutrient content of fresh tuna.

Suggestion

Seeing the results of bacterial identification in boiled tuna negative, then the way cob boiled fish production in Ciawi market can be developed in terms of hygiene health. Should be examined about the causes decreased levels of protein and fat content sizeable increase. Do sharing between merchants boiled tuna to improve the quality of boiled tuna particularly the levels of nutrients, because each trader has its own advantages.

REFFERENCES

- Barasy, M.E. 2005. *At a Glance Ilmu Gizi*. Alih Bahasa Hermin Halim, Jakarta : PT Erangga.
- Georgiev L, Penchev G, Dimitriv D, Pavlov A. Structural changes in common carp (*Cyprinus carpio*) fish meat during freezing. *Bulgarian Journal Of Veterinary Medicine* 2008;2(2):131-136.
- Ghozali T, Dedi M, Yaroh. Peningkatan daya tahan simpan sate bandeng (*Chanos chanos*) dengan cara penyimpanan dingin dan pembekuan. *Infomatek Jurnal Informatika, Manajemen dan Teknologi* 2004;6(1):51-66.
- Hadiwiyoto, Suwedo, 1993. *Teknologi Pengolahan Hasil Perikanan. Jilid I*. Yogyakarta : Liberty

- Hafiludin. Karakteristik Proksimat dan Kandungan Senyawa Kimia Daging Putih dan Daging Merah Ikan Tongkol (*Euthynnus affinis*). *Jurnal Kelautan* (ISSN : 1907-9931). 2011;4(1)
- Hiariey, S dan Vannesa L. Pengaruh pemberian ekstrak biji atung sebagai pengawet alami terhadap perubahan nilai mutu ikan tongkol asap. *IPHPI* 2015.18(3):329-340 available online: journal.ipb.ac.id/index.php/phpi
- Heruwati, ES. Pengolahan ikan secara tradisional: prospek dan peluang pengembangan. *Jurnal Penelitian dan Pengembangan Pertanian*. 2002.21(3):3-4.
- Mao L. W Tao. 2008. Influence of hot air drying and microwave drying on nutritional properties of grass carp (*Ctenopharyngodon edellus*) fillets. *Food Chemistry* 110:647-653.
- Mardiana, N., Waluyo S., Ali M. Analisis kualitas ikan sembilang (*Prarplotosus albilabris*) di kelompok pengolahan ikan Mina Mulya, Kecamatan Pasir Sakti Lampung Timur. *Jurnal Teknik Pertanian Lampung*. 2014.3(3):283-290.
- Palupi, NS., FR Zakaria dan E Prangdimurti. 2007. *Pengaruh Pengolahan terhadap Nilai Gizi Pangan* Modul e-Learning ENBP, Departemen Ilmu & Teknologi Pangan-Fateta-IPB
- Sanger G. Oksidasi lemak ikan tongkol (*Auxfs thazardl*) asap yang direndam dalam larutan ekstrak daun sirih. *Pasific Journal*. 2010;2(5):870-873.
- Stolyhwo A, Sikorski ZE. Polycyclic aromatic hydrocarbon in smoked fish—a critical review. *Food Chemistry* 2005;91:303-311.
- Swastawati F, Eko S, Bambang C, Wahyu AT. Sensory evaluation and chemical characteristics of smoked stingray (*Dasyatis blekeery*) processed by using two different liquid smoke. *International Journal of Bioscience, Biochemistry and Bioinformatics*. 2012;2(3):212–216.
- Widiastuti, I.. Bakteri patogen pada ikan pindang dalam kadar garan yang berbeda. *J Ilmiah Santina*. 2005:2(3):279-287.
- Winarno FG. 2008. Kimia Pangan dan Gizi. Ed. Terbaru. Jakarta: M Brio Press.

INTESTINAL PARASITER - ZONOSIS DISEASE STUDY OF GOAT IN GORONTALO DISTRICT

¹Tri Ananda Erwin Nugroho, ²Nibras K. Laya, ³Sarifudin H. Hiola, ⁴Sarwono S. Prasejo,
⁵Herman S. Wahab
Department of Animal Husbandry, Faculty of Agriculture - Gorontalo State Of University
ababil.nugroho@gmail.com

ABSTRACT

The purpose of this study is to conduct studies of parasitic disease-zoonosis digestive tract in goat in Gorontalo regency. The results of this study in the long term is expected to contribute to the local government of Gorontalo in the development of livestock sector, especially in terms of handling disease in goats and anticipation of the potential diseases of parasiter-zoonosis of goats. Some examples of parasitic diseases by worms include Fasciola sp., Schistosoma sp., Haemonchus sp., Toxocara sp., Taenia sp., Trichuris sp., And others. While parasitic diseases by protozoa include Coccidia sp., (Eimeria sp., Toxoplasma), Balantidium sp., Entamoeba sp., And Giardia.

Goat farms in Gorontalo Regency were selected in the study because this district has the highest number of goats compared to other regencies in Gorontalo Province. Determination of the number of samples using Slovin equation with 90% cofidensi rate, then the sample is taken proportionally. The research method was done by checking the goat faeces using native inspection and floatation. The next object was observed using a binocular microscope with 400 times magnification. The incidence rate of parasitic-zoonotic disease in goats was determined by counting the number of positive samples of parasite agents divided by the number of samples examined multiplied by one hundred percent.

The results of the study found 52% worm Nematoda, consisting of Haemonchus Sp. Worms, Strongylus Sp., Trichuris Sp., Strongyloides Sp., And worms OstertagiaSp .; Next Trematoda worm as much as 37% consisting of worms Eurytrema Sp., Paramphistomum Sp., Schistosoma Sp., And FasciolaSp .; and 2% Cestoda worms. While digestive protozoa found 35%. It consists of Coccidia oocysts of the Eimeria Sp. Species, and the oocyst Entamoeba Sp.

Schistosoma sp., Coccidia sp., (Toxoplasma) and Taenia sp., (Cestoda) are potential diseases of the gastrointestinal parasitic zoonoses of goats present in Gorontalo District.

Keywords: Study, Parasiter-zoonosis, Schistosoma, Coccidia, Cestoda, feses, goat, Gorontalo.

ANALYSIS OF FACTORS THAT CONTRIBUTE TO TARGETS BABY VISIT IN HALMAHERA CLINIC SEMARANG

Muhammad Iqbal*, Bambang Wahyono

Email : iqbalinferno@yahoo.com

Jurusan Ilmu Kesehatan Masyarakat Universitas Negeri Semarang Kampus Sekaran

Gunung Pati Semarang 50229 Jawa Tengah-Indonesia Telp. (024) 8508007

Email : fik-unnes-smg@telkom.net

ABSTRACT

Based the data from the performance of Halmahera health centre shows that of in 2010 showed that babies visit only reached 74%, in 2011 reached 72%, in 2012 reached 100%, and in 2013 fell to 72%. The purpose of this research was to determine the factors that affect achievement of program targets baby visits in Halmahera health centers in 2013. The research was a descriptive qualitative data collection was done by interview, observation and documentation. Number of key informants were the 3 people and number of informant triangulation was 1 person. The results showed the influence of input component related to the lack of human resources to the components associated process of organizing the resulting confusion in the division of desk jobs on the program visit the baby, it has been an impact the quality of service and patient interest to visit the baby visit program at the Halmahera health center. The advice of researchers are constantly analyzing the positions of each year and maximize the existing human resources to set up a schedule shifts so that all programs can be covered by existing human resources

Keywords : *Organizational Resources, Outcomes Target Community Health center*

Community Health Center Management

FACTORS ASSOCIATED WITH DISABILITY ON LEPROSY PATIENTS

Nanang R. Paramata¹, Zuhriana K. Yusuf², Wirda Y. Dulahu³
Health and Sport Faculty, Ners Programme Study, Gorontalo State University,
Gorontalo, Indonesia.

Correspondence Email: nanangroswita@yahoo.co.id,¹ wirda@ung.ac.id³

ABSTRACT

Leprosy is a disease, especially known and feared because of the nerve function impairment and disabilities that can result. Until now, leprosy have remained became a public health problems in Indonesia with high rates of disability and Leprosy is one of the infectious diseases that can cause very complex problems. The problem is not only in medical terms but extends to social, economic, cultural, security and national health issues.

The objective of the study was to identify the relationship between age, sex, economic level, level of education, types of leprosy, level of knowledge, personal hygiene, density residential, with disability.

The study was observational with cross sectional design. The population in this study were all patients of leprosy in Gorontalo City who had completed their medication from 2015 to 2017, Totaling 87 People. Data were obtained from interviews and questionnaire. Amount sample of this research is 25 respondents obtained with purposive sampling. The result of this research show that significant associated between level of knowledge with disability, ($p=0.003$). Factors age, sex, economic level, level of education, types of leprosy, personal hygiene, density residential there was not associated with disability.

The conclusion that was a significant association between level of knowledge with disability, and important for the health care profession to increase knowledge with health promotion to leprosy patients to prevent disability.

Keywords: Leprosy, disability

EFFECTIVENESS OF NUTRITIONAL MENTORING IN IMPLEMENTATION OF ENERGY CONSUMPTION AND NUTRITION STATUS ON TAEKWONDO ATHLETES

Irwan Budiono*

*lecturer of Nutrition Department of Sport Science Faculty UNNES

ABSTRACT

Good nutritional status is one of the important factors in achieving sports achievement. Preliminary study data on Taekwondo athletes at BPPLOP (Education and Training Student Training) Central Java Province showed 33% of athletes have less nutrition. This situation indicates the need to improve the nutritional status of athletes. For that we need a mentoring program to improve the nutritional status of athletes.

This action research is conducted to help increase energy intake in athletes. Univariate analysis was performed to determine the size of the central tendency of data from the body mass index variables and the level of energy consumption. The wilcoxon rank test is used to determine the significance of different research variables during the research cycle.

The results showed an improvement in body mass index and percentage level of energy consumption in athletes during the research cycle. Wilcoxon rank test results also showed that athlete assistance in regulating food intake significantly increased the percentage of energy intake with $p = 0.018$. Athlete mentoring also can effectively improve the body mass index of athletes with $p = 0.011$.

Athlete assistance in the regulation of food intake proved to be effective in increasing the percentage of energy consumption level and body mass index. Therefore, it is suggested that the efforts of athlete assistance and develop the instruments that facilitate the athletes in regulating food intake.

Key words : Athlete mentoring, energy intake, body mass index

ASSISTANCE OF HEALTH VOLUNTEERS IN INTEGRATED POST SERVICE TOWARD THE PATTERN OF COMPLEMENTARY FEEDING AMONG 6-24 MONTHS OLD IN SUKOHARJO REGENCY

Ainur Rohmah¹, Mardiana^{1*}, Lukman Fauzi¹

¹ Public Health Science Department, Universitas Negeri Semarang, F5 Building
2nd Floor, Sekaran Campus, Gunungpati, Semarang City

*Corresponding email: mardiana.ikm@mail.unnes.ac.id

ABSTRACT

Children 6-24 months old should be given complementary foods. The prevalence of malnutrition in Tegalmade village was 6.12%. It caused because of mother gave their children complementary food of breast milk earlier. The purpose of this study was to determine the assistance of health volunteers in integrated post service toward the pattern of complementary feeding among 6-24 months old in Sukoharjo Regency.

Type of this research is *Quasy Experiment with Non Equivalent Control Group design*. The population of this research all mothers with infant 6-24 months old who live in the village Tegalmade . The sample was selected using a sampling technique propoive sampling , to obtain a sample of 22 mothers. Results were analyzed using the *Mann-Whitney* test to know the effectiveness of assistance of healthy volunteers in integrated post service toward the pattern of complementary feeding among 6-24 months old in Sukoharjo Regency .

The results showed a significant difference between two groups ($p=0,047$). It means there was effectiveness assistance of health volunteers in toward pattern of complementary feeding.

Keywords : Infant, Mother, Complementary food of breast milk, health volunteers

CHANGES OF AMINO ACID CONTENT IN MANGGABAI FISH OF FERMENTATION RESULTS

Faiza A. Dali*, Rita Marsuci Harmain

Teknologi Hasil Perikanan, Fakultas Perikanan dan Ilmu Kelautan, Universitas Negeri Gorontalo, Jalan Jenderal Sudirman No. 6 Kota Gorontalo, 96128 Gorontalo
Telp (0435) 821125, Faks (0435) 821752

*Korenspondensi: dali.faiza@yahoo.co.id

Abstract

This study aims to determine the content of amino acids in fresh manggabai fish and fermented products. Manggabai fresh fish obtained from fishermen in the waters of Limboto lake, Gorontalo. Manggabai fish washed, cut into small pieces then fermented with 15% salt mixture, 20% and 40% carbohydrates for 15 days anaerobically at $\pm 45^{\circ}\text{C}$. Amino acid testing was performed on fresh manggabai fish and dried fermented products. Test results obtained that fresh manggabai fish and fermented products contain the highest amino acids in glutamic acid and the lowest in histidine. Levels of amino acids contained in manggabai fish increased after the fermentation process with carbohydrate 20%. The existence of fermentation technology can increase the nutritional value of manggabai fish. The amino acid content decreases in value after fermented 40% carbohydrate.

Keywords: manggabai fish, Limboto lake, salt, carbohydrate

PRELIMINARY

Foods that have many benefits for human health include fish. Currently the Indonesian people have a consumptive nature of fish, due to the nutritional content of fish, especially proteins that are needed to stabilize the performance of the human body. Fish meat has shorter protein fibers than protein fibers of chicken and beef.

Fish protein content of 15-25% w / w composed of amino acids. The content of amino acids in fish meat varies depending on the type of fish. One of the freshwater fish that people love Gorontalo is manggabai fish, living in the waters of Lake Limboto. Suryandari and Krismono (2011) stated that biologically manggabai fish are carnivorous fish and spawn more than once a year. Gorontalo people consume manggabai fish in the form of fried foods, broth or baked. Utilization of manggabai fish to be a variety of food has not been optimally done, especially to avoid fish from decay.

Fermentation includes processing technology in preserving fish by utilizing enzymes in fish tissues and microorganisms. During the fermentation process the food will undergo changes in physical and chemical properties. Fermented food products made from fish, for example in Indonesia, namely bakasang (Yanti and Dali 2013), former (Nuraini et al 2014), peda (Thariq et al 2014), terasi (Suwandi et al 2017). Fish fermented products are also found outside of Indonesia, for example in India called Lona ilish (Majumbar and Basu 2010).

Carbohydrate sources for the fermentation process are limited in the fish body, so additional carbohydrates are needed from the outside. Carbohydrates in the fish body mostly in the form of polysaccharides is glycogen. Kalista et al. (2012) states that the amylopectin content in rice flour is lower than other carbohydrate sources, so the bacteria more easily use it as a medium for growth of BAL and better fermentation results. Carbohydrates, protein and fat in fish is a medium used as a source of nutrients for microorganisms that play a role in the process of fermentation. The fermentation process is influenced by several factors such as acid, temperature and oxygen (aerob or anaerob). This study was conducted with the aim of knowing the amino acid content in fresh mangabai fish and fermented products.

METHOD

Tools and materials

The equipment used in this study includes incubators, ovens, scales, large basins, knives, cutting boards, gloves and masks. The materials used, namely fresh manggabai fish purchased directly to fishermen on the coast of Limboto lake, salt and carbohydrates.

Research procedure

The fresh manggabai fish are washed with ice water, then the fish is drained, cut into small pieces to facilitate the process of mixing the ingredients. The fish was then weighed, then mixed with 15% salt and 20% floured carbohydrate (C) and 40% (D) of the starchy carbohydrate. After mixing the ingredients, the sample was put into a sealed container and incubated at $\pm 45^{\circ}\text{C}$ for 7 days, then dried at 60°C for 8-12 hours, then fermented again for 8 days.

Fresh manggabai fish and fermented products were then tested for amino acid content. Test method for amino acid content in manggabai fish using HPLC (High Performance Liquid Chromatography).

RESULTS AND DISCUSSION

Amino Acid Fish Manggabai Fresh

The non essential content of amino acids in raw mangabai fish feedstock showed that the highest level was glutamic acid of 1.6%, followed by aspartic acid 0.97%, while the lowest value in tyrosine was 0.32%. The highest essential amino acid content in lysine and the lowest in histidine.

Maggabai fish have glutamic acid that can be used as a flavoring agent, as well as aspartic acid. Mouritsen (2012), reported amino acids aspartate can provide a savory taste (umami) after the amino acid glutamate.

Fermented Amino Acid

Fermentation of mangabai fish with 15% salt and 20% carbohydrate (C treatment) shows differences in amino acid levels. The highest non essential essential amino acid content in glutamic acid was 3.41% and the lowest in serine was 0.76%, while the highest essential amino acid in leucine was 1.62% and the lowest in histidine was 0.29%.

Treatment with 40% carbohydrate (D) showed changes in amino acid levels after fermentation. Non essential essential amino acids have the highest value on glutamic acid of 3.17% and the lowest in serine is 0.64%, while the highest essential amino acid in leucine is 1.57% and the lowest in histidine is 0.31%.

Fresh mangabai fish and fermented products obtain varying amino acid values. The nutritional value of amino acids is increased through the fermentation process can provide added value to mangabai fish for consumption. Pawiroharsono (2007), explains the benefits of fermented food products such as the value of nutritional food increased due to the formation of new nutrient compounds metabolism results. The results of the analysis can be seen in Table 1.

Table 1. Amino Acid Content In Maggabai Fish

Asam Amino	Manggabai (%)		
	Manggabai Segar	C (20%)	D (40%)
Non esensial :			
Asam Aspartat	0,97	1,84	1,73
Asam Glutamat	1,6	3,41	3,17
Alanin	0,64	1,45	1,15
Glisin	0,5	1,17	0,77
Serin	0,39	0,76	0,64
Tirosin	0,32	0,99	1,02
Esensial :			
Arginin	0,57	0,84	0,74

Histidin	0,19	0,29	0,31
Isoleusin	0,45	1,12	1,09
Leusin	0,77	1,62	1,57
Lisin	0,88	1,15	1,11
Metionin	0,29	0,54	0,6
Penilalanin	0,42	1,04	0,97
Treonin	0,37	0,64	0,61
Valin	0,47	1,25	1,23

Graphically the Amino Acid Content in Manggabai Fish is fresh, the fermentation of C (20%) and D (40%) both non essential and essential can be shown in Figure 1.

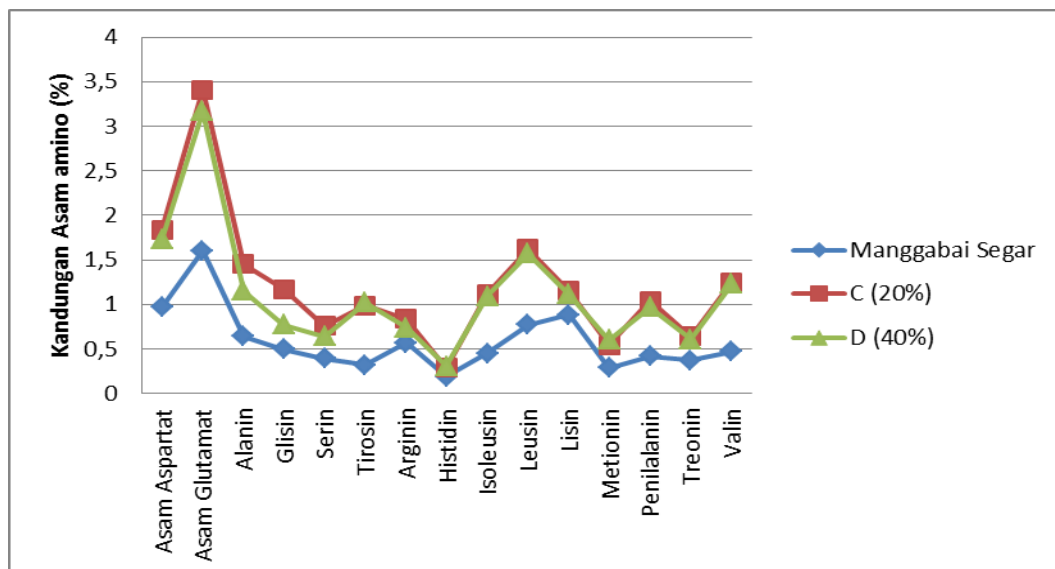

Figure 1. Amino Acids content in fresh Manggabai fish, fermented C (20%) and D (40%)

CONCLUSION

Changes in amino acid levels contained in manggabai fish occur in the presence of fermentation technology. The fresh manggabai fish and fermented yields of amino acids vary with the highest levels of glutamic acid and the lowest in histidine. Fish manggabai after fermented with 20% carbohydrate, the value of amino acid nutrition has increased.

THANK-YOU NOTE

Thanks to the UNG Research Institute and the RISTEK DIKTI Ministry for the support of the Competitive Grants scheme.

BIBLIOGRAPHY

- Kalista A, Supriadi A, Rachmawati SH. 2012. Bekasem ikan lele dumbo (*Clarias gariepinus*) dengan penggunaan sumber karbohidrat yang berbeda. *Fishtech* 1(1):102-110.
- Majumbar RK, Basu S. 2010. Characterization of the traditional fermented fish product of *Lona ilish* of Northeast India. *Indian Journal of Traditional Knowledge* 9 (3): 453-458.
- Mouritsen AG. 2012. Umami flavour as a means of regulating food intake and improving nutrition and health. *Nutrition and Health* 21 (1):56-75.
- Nuraini A, Ibrahim R dan Rianingsih L. 2014. Pengaruh penambahan konsentrasi sumber karbohidrat dari nasi dan gula merah yang berbeda terhadap mutu bekasam ikan nila merah (*Oreochromis niloticus*). *Jurnal Saintek Perikanan* 10 (1): 19-25.
- Pawiroharsono S. 2007. Potensi pengembangan industri dan bioekonomi berbasis makanan fermentasi tradisional. *Jurnal Ilmu Kefarmasian Indonesia* 5 (2): 85-91.
- Thariq AS, Swastawati S, Surti T. 2014. Pengaruh perbedaan konsentrasi garam pada peda ikan kembung (*Rastrelliger neglectus*) terhadap kandungan asam glutamat pemberi rasa gurih (*umami*). *Jurnal Pengolahan dan Bioteknologi Hasil Perikanan* 3 (3): 104-111.
- Suryandari A dan Krismono. 2011. Beberapa aspek biologi ikan manggabai (*Glossogobius giuris*) di danau Limboto, Gorontalo. *Bawal* 3 (5): 329-336.
- Suwandi, Rohanah A, Rindang A. 2017. Uji komposisi bahan baku terasi dengan menggunakan alat pencetak terasi. *Jurnal Rekayasa Pangan dan Pertanian* 5 (1): 196-201.
- Yanti DIW dan Dali FA. 2013. Karakterisasi bakterim asam laktat yang diisolasi selama fermentasi bakasang. *Jurnal Pengolahan Hasil Perikanan Indonesia* 16 (2):132-140.

CONTRIBUTION PERCENTAGE OF FATTY BODY THICKNESS TO PHYSICAL FITNESS INDEX ATHLETE WRESTLING

Rubianto Hadi¹, Rivan Saghita Pratama¹

rubianto.hd@unnes.mail.com, rivan_jateng@hotmail.com

UNIVERSITAS NEGERI SEMARANG

Abstract: Physical fitness index becomes the overall body muscle endurance monitor. Muscular endurance plays an important role in the sport of wrestling, but many athletes wrestling with less endurance due to body fat that is owned by the athletes on average exceeds the normal limit. The problem in this research is whether there is contribution percentage of body fat thickness to physical fitness index athlete wrestling club Garuda city of Semarang in year 2017. The purpose of this research is to know contribution percentage of body fat thickness to physical fitness index athlete wrestling club Garuda Semarang city 2017. Method research Which is used quantitatively with the test survey. The population of this study is Garuda Semarang club wrestling athletes with a sample of 12 athletes. Sampling using a total sampling technique with the criteria of athlete wrestling aged 17-20 years, male sex, has been practicing wrestling at least one year. The research variables consist of free variable that is percentage of body fat thickness, and dependent variable physical fitness index. Data analysis technique used non parametric statistics with kolmogorov smirnov test, homogeneity test and simple regression with data analysis method using computerized calculation of SPSS 21. Result of research body fat thickness known t count = -6,754 with significance value $0,000 < 0,05$ meaning there is influence Negative body fat to the physical fitness index. Body Fat Influence on physical fitness index is 82,0%. The conclusion of this research is the contribution of body fat thickness percentage to physical fitness index of Garuda wrestling club Garuda Semarang city in 2017. Research suggestion: athletes need to reduce body fat by practicing hard and seriously as an effort to increase achievement

INTRODUCTION

Exercise is an activity that brings many benefits to human beings primarily human. The benefits of exercise is to maintain health and fitness, as a means of recreation, as a means of education and for event achievement. Various branches of sport officially contested by the government, including: football, volleyball, basketball, athletics, swimming, gymnastics, martial arts and so on. Martial arts itself many kinds such as: martial arts, karate taekwondo, tarung drajat, kempo, wrestling and etc.

Wrestling is a sport that requires explosive power support, dynamic strength, and isometric, aerobic and aerobic endurance, speed, and flexibility (Andi Li-An Ho). To achieve the achievements of the sport of wrestling not only rely on mastery of technique and mental but also physical components to support the exercise and also in the game. The entire physical component must always be trained and measured periodically.

A wrestler is required to stay in shape to be able to concentrate on attacking or defending. If the level of endurance decreases it will be difficult to get the concentration so that technique, tactic, and also mental can not be done maximally.

Muscular endurance is endurance that involves several muscle groups in their performance. By exerting muscle performance as well as cardiorespiratory ability, one's own endurance can be accelerated by proper practice according to the classification of each endurance itself. With the duration of muscle work is relatively long in the endurance exercise required energy to be able to perform a larger metabolism so quite tightly when associated with fat as a backup energy.

Muscular endurance in the human body is present in several parts of the body separately, although it is interconnected but for measuring it is usually done separately as to measure the endurance of the arm muscles, measure the endurance of the abdominal muscles, measure the endurance of the leg muscles. To measure the overall muscular endurance of the test can be done by The McCloy Physical Fitness Test method, so the value of the muscle endurance level can be calculated and known through the program in the test (Brian Mackenzie, 2010:168)

Fat is an organic substance that is not soluble in water. Fat is composed of carbohydrates and proteins, fat is one source of energy, the source of energy reserves that the body uses when the carbohydrates are exhausted in the

process of energy formation. In the human body there is body fat stored under the skin, everyone has different fat thickness, depending on the area of fat tissue (adipose tissue) that is affected by innate genes, sex, and age.

The stored fat reserves in the body will be used to supply energy to physical activities with long duration because fat in the process of disassembly or can be used through a long process. The fat bonding chain of more fat atoms than any other energy source causes its metabolism to be the longest in the process and also produces larger calories in the same weight as other energy sources. Each person has different body fat levels so that researchers are interested to conduct research on the percentage of body fat influence on muscle endurance.

Through observations made there is data that athletes wrestling club Garuda Semarang city is known to have athletes with skinny body type, ideal and fat. Under these circumstances it is suspected that Garuda's athletes in Semarang city body composition have problems that are suspected to impede their achievement. In addition, according to the authors observation that in some games many wrestling athletes who quickly experience fatigue during the match and also practice.

METHODS

In a study required the selection of methods to obtain results in accordance with the expected objectives.

The population in this study is all junior wrestlers Garuda clubs Semarang clubs in 2017 with a total of 12 people. The population in this study has the following criteria: 1) Wrestling athletes aged 17-20 years, 2) Male gender, 3) Active practice wrestling Garuda club. For that reason, the population taken has qualified as a population that has at least one common trait. Sampling research using total sampling technique that mangambil the entire population as a sample of research. The instrument used is the McCloy Physical Fitness Test Index which consists of 5 types of tests: chins up, press up, squat thrust, squat jump, sit up.

For data analysis used in this research is to use bivariate correlation coefficient analysis.

Hypothesis testing was performed after the prerequisite analysis test included: normality test, homogeneity test, and linearity test. After the three prerequisite

tests are met then the next statistical calculation can be continued hypothesis test.

RESULT AND DISCUSSION

From the calculation of percentage contribution of body fat thickness with physical fitness index of Garuda athlete club of Semarang city in 2017, the calculation result obtained by significance value $0.000 < 0,05\%$ then H_0 (no contribution percentage of body fat thickness to physical fitness index atlet wrestling club Garuda in the Semarang city 2017) rejected, and H_1 (there is contribution of body fat thickness percentage to physical fitness index atlet gulat club Garuda Kota Semarang 2017) accepted. So the hypothesis stating "There is a contribution percentage of body fat thickness to physical fitness index atlet wrestling club Garuda Kota Semarang 2017" received.

The value of R-Square is $0.82 = 82.0\%$. This means the contribution percentage of body fat thickness to physical fitness index athletes club wrestling Garuda in the Semarang city amounting to 82.0% .

Individuals reviewed every fat content of most athletes experiencing advantages over the ideal limit. So it must be considered because the higher fat content value of physical fitness index is lower. With normal body fat levels then Garuda's club wrestling athletes can perform muscle endurance activity as measured by physical fitness index better. Keep in mind if body fat also plays an important role in long-lasting physical activity.

CONCLUSION

Based on the results of research that has been done with data analysis and hypothesis testing, it can be drawn conclusion as follows:

"There is a contribution percentage of body fat thickness with physical fitness index athlete wrestling club Garuda Kota Semarang in 2017".

"The percentage contribution of body fat thickness to physical fitness index of Garuda athlete club in Semarang city of 2017 is 82.0% and the remaining 18.0% is influenced by other factors or variables not studied in this research."

REFERENCES

Andy Li-An Ho (nd). Explosive Power and Anaerobik Endurance for Wrestlers. Online.

- <http://link.springer.com/search?query=endurance+strength+for+wrestling>
(accessed 02/28/17)
- Andryan Setyadharma. 2010. *Uji Asumsi Klasik Dengan SPSS 16.00*. Semarang: Unnes
- AR Shadiqin. 2013. Sistem Energi Dan Latihan Fisik. Online. Available at <http://download.portalgaruda.org/article.php?article=95982&val=5074>
(accessed 3/4/17)
- Ashok, C. 2008. *Test Your Physical Fitness*. Delhi: Kalpaz Publitions.
- Bompa, Tudor O. 2011. *Teori dan Metodologi Latihan*. Terjemahan Sarwono. Surabaya
- Chu, Donald A. and Gregory D. Myer. 2013. *Pyometric*. USA: HumanKinetics.
- Eko AndiSusilo. 2013. Hubungan Persentase Lemak Tubuh terhadap Daya Tahan Kardiorespirasi Atlet Pencak Silat di Klub SMP Negeri 01 Ngungut Tulungagung. Available at <http://ejournal.unesa.ac.id/article.pdf>. (accessed 02/08/17).
- Fakultas Ilmu Keolahragaan. 2014. *Pedoman Penyusunan Skripsi*. Semarang: Unnes
- Grosser. 2001. *Kesehatan Olahraga*. -
- Harsono. 1988. *Coaching dan Aspek-aspek Psikologi dalam Coaching*. Jakarta: LPTK.
- . *Prinsip dan Metodologi Kepelatihan*. -
- Kardjono. 2008. *Modul Mata Kuliah Kondisi Fisik*. Bandung: FPOK UPI.
- Karundeng, Ronny. Sunny Wanko dan Sonny J. R Kalangi. (nd) Jaringan Lemak dan Jaringan Lemak Coklat Aspek Histofisiologi. Online ejournal.unsrat.ac.id/index.php/biomedik/article/download/6328/5848
(accessed 01/19/17).
- M.Sajoto. 1995. Peningkatan & Pembinaan Kekuatan Kondisi Fisik Dalam Olahraga. Semarang: Dahara Prize Self Evaluation Kit. Efek Latihan Fisik Otot. Online. <http://www.hiithighintensityintervaltraining.ga/2016/12/efek-latihan-fisik-pada-sistem-otot.html> (accessed 3/4/17).
- Mackenzie, B. 2005. *101 Evaluation Tests*. London: Electric Word plc
- Mackenzie, B dan Glen Cordoza. 2012. *Power Speed Endurance A skill-Based Approach to Endurance Training*. USA: Victory Belt Publishing Inc.
- Menpora. 2007. *Pelatihan Pelatih Fisik Level I*. Jakarta: Menpora.
- . 2010. *Pelatihan Pelatih Fisik Level II*. Jakarta: Menpora.
- Muhammad Yobbie Akbar. 2013. "Kemampuan Daya Tahan Anaerobik dan Daya Tahan Aerobik Pemian Hoki Putra Universitas Negeri Yogyakarta". *Skripsi*. Fakultas Ilmu Keolahragaan Universitas Negeri Yogyakarta.
- Noorf. 2015. *Batasi Gula Garam Lemak dengan G4 G1 L5*. Available at <https://dinkes.gunungkidulkab.go.id/batasi-gula-garam-lemak-dengan-g4-g1-l5/> (accessed 3/4/17).
- National Strength and Conditioning Association. 2012. *Developing Endurance*. USA: Human Kinetics.
- Nisful Fitra. (nd) Hubungan Persentase Lemak Tubuh Terhadap Kemampuan Vo2max pada Atlet Gulat Kota Surabaya. Online. <http://ejournal.unesa.ac.id/article/18523/66/article.pdf> (accessed 03/01/17).
- Nur Fitria Ratnasari. 2006. *Hubungan Antara Kekuatan Otot Tungkai dan Kekuatan Otot Punggung Dengan Kecepatan Bantingan Pinggang Pada Atlet Gulat Kota Semarang Tahun 2006*. Skripsi. Universitas Negeri Semarang.
- Rubianto Hadi. 2014. *Buku Ajar Gulat*. Semarang: Unnes Press

- Self Evaluation Kit. Faktor-Faktor Yang Mempengaruhi Kapasitas Aerobik atau Kebugaran Jasmani. Online.
<http://www.hiithighintensityintervaltraining.ga/2016/01/faktor-faktor-yang-mempengaruhi-kapasitas-aerobik-atau-kebugaran-jasmani.html>(accessed 3/4/17)
- Self Evaluation Kit. 2016. Online. <https://read01.com/MeP7az.html> (accessed 06/14/17).
- Sharkey,B. J. 2003. *Kebugaran dan Kesehatan*. Jakarta: Fajar Interpratama.
- Sugiyono. 2011. *Metode Penelitian Kuantitatif Kualitatif dan R&D*. Bandung:Alfabeta.
- SuharsimiArikunto. 2013. *Prosedur Penelitian Suatu Pendekatan Praktik*. Jakarta: Rineka Cipta
- Sukadiyanto. 2011. *Pengantar Teori Metodologi Melatih Fisik*. Bandung: Lubuk Agung.
- Sulistiono. 2015. *Hubungan Ketebalan Lemak Dengan Daya Tahan Atlet Gulat Pelatda Jateng 2015*. Skripsi. Universitas Negeri Semarang.
- Thompson, Peter JL. 1991. *Introduction to Coaching Theory*. Inggris: Marshallarts Print Services Ltd.
- UU RI No. 3 Th. 2005. Sistem Keolahragaan Nasional.

THE EFFECT OF THEOBROMINE AND CAFFEINE ON THE LEVEL OF MUSCLE FATIGUE AFTER PHYSICAL ACTIVITY MAXIMUM

Sugiarto¹, Taufiq Hidayah¹ dan Aan Wahyu Setiawan¹

¹Sport Science Department, Faculty of Sport Science
Universitas Negeri Semarang

sugiarto.edu@mail.unnes.ac.id

ABSTRACT

The objective of research proves that the comparison theobromine and caffeine administration prior maximum physical activity and determine the level of muscle fatigue which it does not get fluid theobromine and caffeine, determine the level of muscle fatigue in the group receiving fluids theobromine and caffeine.

Quantitative research methods to the design scheme random post test control group design (Experimental laboratory). The research variables are: (1) The independent variables: the provision of theobromine and caffeine (2) The dependent variable: lactic acid levels to determine the level of muscle fatigue. Population of 18 male rats wistar strain with the withdrawal of sampling the "total sampling" by using 18 rats were divided into three groups with each group of 6 samples. Blood is then taken through a rat's tail were analyzed using accutrend plus tools to measure the levels of lactic acid. Data analysis is using descriptive analysis using SPSS version 16.

The results of the study lactic acid levels in the control group was (5.2 mmol), group 1 amounted to (4.9 mmol), group 2 (4.2 mmol). In the test proved sig f 0.76 (<0.05). While the calculation of the weight of the control group rats (202.1 g), in group 1 (192.5 g), and the 2 treatment groups was (174.8 grams).

The conclusions and recommendations of this research is the provision of theobromine and caffeine on maximal physical activity did not significantly affect the level of muscle fatigue, the researchers suggest not to consume theobromine and caffeine to prevent the maximum fatigue of muscles after physical activity.

Keywords: Theobromine; Caffeine; Muscle fatigue; Lactic acid; Physical activity

INTRODUCTION

According to the World Health Organization (WHO), physical activity was defined as body movement produced by skeletal muscles that requires energy expenditure. Moving / activity is any body movement that increase energy expenditure and energy (burning calories), so it can be concluded that physical activity is all sorts of motion that requires energy.

Physical activity greatly affect a person's physical fitness, especially activity that contributes directly to the freshness of physical component. The physical activity must be adapted to the child's age, safety factors and the equipment used physical activity can not be done haphazardly remains to be done with the technique and the correct rules. Likewise for teens and adults physical activity need to be familiar with the characteristics of the sport to be played so it does not pose a risk of fatal injury. Although they enjoy in sports still have to see the age and physical condition so that it remains well controlled (Toho Cholik Mutohir and Muhammad Muhyi, 2011: 25).

As long as we do physical activity, muscle will require a lot of energy to move. The amount of energy required depends on how much muscle that moves, how long time and workload. In aerobic activity is a sporting activity with mild-moderate intensity that can be carried out continuously and in a long time (Giri Wiarto, 2013: 131 & 140). Activities and games that produce an activity which called a leisure activity most sports such as wrestling and archery developed from activities that are critical to survival. In addition to the pleasure of sport and physical activities is also important in building activities and keep in shape (Lala Herath, 2008: 33).

Fatigue is the decrease of the quantity, quality of labor or the exercise that caused by (result of) perform work or a particular sport.

Deterioration in the quality and quantity of work or exercise is due to the intensity and duration of work or exercise it causes disruption of homeostasis (Santosa Giriwijoyo & Dikdik Zafar Sidik, 2012: 272).

If the lactic acid will be eliminated quickly through the mechanism of oxidation to power for meresintesis ATP from ADP and meresintesis glycogen from lactic acid, so that there will be no trash buildup of lactic acid. Thus, the lactic acid will not cause fatigue. Instead advantages of using fat as an energy source is that fat does not produce lactic acid so it does not cause fatigue on exertion (Santosa Giriwijoyo & Dikdik Zafar Sidik, 2013: 414).

Basically, chocolate is good, except the calories are high. Every 100 grams of cocoa powder to save 298 calories, largely the contribution of calories from 23.8 grams of 'good fats'. Another advantage of the chocolate is able to burn your sex drive. In addition, chocolate can refresh the body sluggish due to fatigue and mood was dull. While cocoa beans contain about 600 chemical components and about 230 are considered beneficial to health. Most of these components such as polyphenols (or flavonoids) that is capable of acting as.

Hence there are a lot of studies using caffeine because the most important effects of caffeine may mobilizing fatty acids which are then used as fuel, burning glycogen. It can be useful to improve endurance, but the diuretic effects of caffeine may damage especially in hot temperatures. Caffeine is also a stimulant (stimulant), and can be petrified to branches that require power and durability (Rusli Lutan, et al, 2000: 81).

The previous research suggests that consuming caffeine in coffee powder amount of 4 mg / kg body weight is the amount that is efficient to provide ergogenic effects and can also oxidize fat in the body (Acheson et al, 1980: 2). The aim of this study is to know the effect of theobromine and caffeine in the control group and the treatment group of the lactic acid levels to examine the degree of muscle fatigue.

RESEARCH METHOD

The research method that used in this research is quantitative. The study design was an experimental laboratory post test random control group design (Suharsimi Arikunto, 2007: 207). The independent variables used are theobromine and caffeine administration prior maximum physical activity and the dependent variable in this study is the lactic acid levels to determine the level of muscle fatigue. The population in this study were male rats wistar strain amounted to 18 heads. The sample in this study is 18 heads were made in total sampling were divided into three groups: control group, the group of theobromine treatment and treatment of caffeine group, each group consist of 6 animals each group from age 2-3 months, weight 150 - 250 grams.

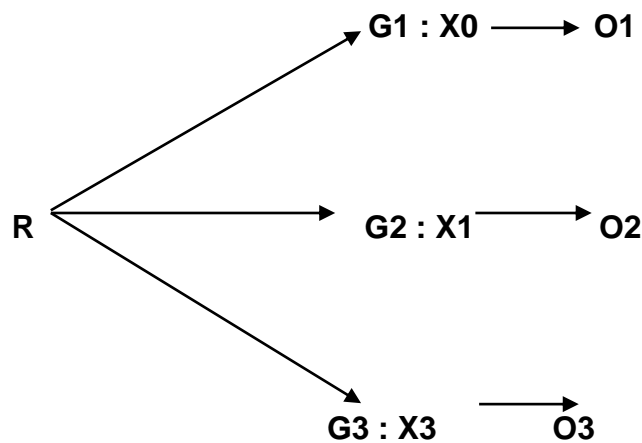

Figure 1. Model of Mindset

Research was conducted at the Laboratory of Department of Biology, State University of Semarang, starting from 11 January until 25 January 2016. On the first day until the seventh day to adapt the respective third parties, after adaptation eighth day until the fourteenth day of adaptation to the treatment group theobromine and caffeine with their maximum physical activity swimming stress to each group. On day 15 were post-test is measurement after administration of theobromine and caffeine treatment with physical activity for a maximum of one week, to know the result of lactic acid levels in the control group, the treatment group of theobromine

and caffeine group on male rats wistar strain. Analysis of the data in this study is using SPSS 16.

RESULTS AND DISCUSSION

Description of Data

1. Description of Data

Weight loss results can be seen as below:

Table 1. The description of sample weight of research

n(6)	Data body weight of rats (gram)		
	Control	theobromine	Caffein
	189	166	178
	214	196	159
	155	212	157
	232	195	226
	206	222	156
	217	164	173
Amount	1213	1155	1049
Average	202.1	192.5	174.8

Sources: Primary data are processed, 2017

2. Results of Data Analysis

2.1 The effect of theobromine and caffeine Against Lactic Acid Levels

Table 2. The effect of theobromine and caffeine Against Lactic Acid Level

	Data Result <i>Posttest</i> Lactic Acid Levels Rats(mmol)		
	Control	Theobromine	Caffein
	3.80	3.60	3.20
	4.30	5.30	3.40
	4.80	3.40	5.70
	5.10	4.30	3.90
	5.70	5.60	4.60
	7.40	7.20	4.10
Average	5,2	4,9	4,2

The data above shows the average levels of lactic acid in male rats wistar strain after the treatment in the control group was 5.2 mmol, the

group was 4.9 mmol theobromine and caffeine group was 4.2 mmol. In the group of caffeine and the provision of physical activity a maximum value-lactic acid levels were lower compared to the control group or a group of theobromine, which states that theobromine coupled with physical activity is effective to reduce lactic acid levels significantly but not significant in comparison with the provision of theobromine and activities swimming.

Data obtained during the measurement of lactic acid levels prior to the data analysis, the normality test data using the Kolmogorov-Smirnov, the data is normal if significant values > 0.05 . Normal distribution of data performed parametric test, the data were not normally distributed nonparametric test. Different test on a normal distribution of data, the data is tested by one way ANOVA test while if the data is not normally tested with Kruskal Wallis test. Normality test results data using the Kolmogorov-Smirnov obtained the following results.

Table 3. Data Normality lactic acid levels post-test control group, treatment 1 and treatment 2 by Kolmogorov-Smirnov

Variable	Kolmogorof-Smirnov	ρ
Control group (n=6)	0,472	0,979
Treatment group 1 (n=6)	0,398	0,997
Treatment group 2 (n=6)	0,462	0,983

Sources: Primary data are processed, 2017

Normality test results above with kolmogorof-Smirnov normal distribution of data obtained ($\rho > 0.05$) in both groups dick post-test, post-test and post-treatment 1 treatment test 2

Homogeneity Test Data

Homogeneity test variables using the homogeneity test Chi-Square, the data post-test in this study were tested parametric whereas distribution is not normally tested non-parametric, with further testing is done to determine whether the data are homogeneous or not, the data is said to be homogeneous if sig ($\rho > 0.005$). Homogeneity test was

conducted to determine the lactic acid test data (mmol) in the control group and the treatment group. The results show the data homogeneous ($p > 0.005$), shown in table 4.4

Table 4. Data Homogeneity lactic acid levels post-test control group, treatment 1 and treatment 2 by Chi Square

Variable	Chi Square	p
Control group (n=6)	0,001	1.000
Treatment group 1 (n=6)	0,001	1.000
Treatment group 2 (n=6)	0,001	1.000

Sources: Primary data are processed, 2017

The table above can be seen that the data showed a significant value in the control group, the treatment group 1 and group 2 treatment was > 0.05 , it can be concluded that the data homogeneous or equal.

Hypothesis test between groups post-test research

Test the hypothesis in this study is used to determine whether there is a comparison of lactic acid levels between the control group, the treatment group theobromine and caffeine treatment group. The average yield of the control group (5.2 mmol), the average group of theobromine (4.2 mmol) and the average in the caffeine group (4.9 mmol). The average yield of lactic acid levels tested the hypothesis by Anova. The hypothesis of this study are as follows.

Ho: No comparisons lactic acid levels between the control group, the treatment group 1 (theobromine), and group 2 (caffeine).

H1: The presence of lactic acid levels comparisons between the control group, the treatment group 1 (theobromine), and group 2 (caffeine).

Table 5. Hypothesis testing ANOVA

	ANOVA				
	Sum of Square	df	Mean Square	F	Sig.
Between	3.421	2	1.711	1.145	0.34

Groups			
Within	22.403	15	1.494
Groups			
Total	25.824	17	

Sources: Primary data are processed, 2017

The results of the research showed that there was no comparison of lactic acid levels between the control group, the treatment group 1 and group 2. These results prove the treatment of the value of $F = 0.332$ with sig 0.76, the alternative hypothesis (H_1) is accepted if sig < 0.05 , because sig $0.76 > 0.05$ so that the null hypothesis (H_0) is received, means there is no comparison of lactic acid levels, among the control group, the treatment group 1 and group 2 treatment had no effect on levels of lactic acid during the 7 days of treatment and activity maximum physical.

Data are presented below for more details on comparative testing lactic acid levels between the control group, the treatment group 1 and 2 treatment groups using the t test. The calculation of the average comparative test data is presented in the table below.

DISCUSSION

The results showed a comparison of lactic acid levels between treatment groups 1 with the treatment of 0.7 mmol 2. So it does not look significant data, which may show a comparison of lactic acid levels, among the control group, the treatment group 1 and group 2 treatment had no effect on levels of lactic acid after physical activity for 7 days. Suggests that the administration of fluids with caffeine theobromine has not provided effective significantly to changes in levels of lactic acid to each sample group. Decreased levels of lactic acid can not be known significantly because the data in this study did not use the data pre-test, a decrease in lactic acid levels are not viewable significance. The results show lower lactic acid levels compared.

Sample the first treatment with fluids theobromine at 0.9 mg per gram of body weight of 150-250 strain Wistar male rats, during the 7 days of treatment with a given maximum physical activity (swimming stress) the results obtained lactic acid levels lower than the control group. The average levels of lactic acid in the treatment group 1 amounted to 4.9 mmol, whereas lactic acid levels in the control group was 5.2 mmol. There is an average difference of 0.3 mmol. In case buildup of lactic acid causes muscle fatigue that resulted in disruption of homeostasis endless source of energy, disruption of metabolism, electrolyte balance disorders in muscles and loose adhesion mechanism of myosin-actin. (Santosa Giriwijoyo and Didik Zafar Sidik, 2012: 139). Basically, chocolate is good, except the calories are high. Every 100 grams of cocoa powder to save 298 calories, largely the contribution of calories from 23.8 grams of 'good fats'. Another advantage of the chocolate is able to burn your sex drive. In addition, chocolate can refresh the body sluggish due to fatigue and mood was dull. While cocoa beans contain about 600 chemical components and about 230 are considered beneficial to health. Most of these components such as polyphenols (or flavonoids) that is capable of acting as antioxidants (Base Idea 2008: xiv).

The comparison of the average ratio of caffeine administration (treatment 2) at a dose of 0.9 mg per body weight of 150-250 gram male rats wistar strain, as long as one week of treatment compared to the control group had a difference of 1.0 mmol with an average of lactic acid control group 5.2 mmol and 2 treatment groups was 4.2 mmol. That administration of caffeine decreased levels of lactic acid tetpi no significance. Caffeine is a central nervous system stimulant, can cause diures, stimulates the heart muscle and relaxes the smooth muscle of the bronchus. In a standard dose of 50-200 mg of caffeine primarily affects the outer layer of the brain. This influence can reduce fatigue. Levels of caffeine contained in robusta coffee beans is 2%, while arabica coffee is

1%. While polyphenol is a chemical compound that works as a powerful antioxidant in coffee (Almada, 2009, Vanzaitan 2010, and Lelyana 2008).

Fulfillment of energy during physical activity obtained through metabolic processes. Metabolism is a chemical process that allows the cells to be able to carry out his life. Another definition of metabolism is throughout the chemical changes that occur in the body. The body converts food into energy through a few different paths. The energy required for muscle contraction is obtained from food substances that are consumed every day. But in general can be divided into aerobic and anaerobic pathways. Both of this lane are translated into three lines that occur in physical activity for muscle contraction (Giri Wiarto, 2013: 141).

People who doing exercise with high intensity until exhaustive, They produce free radicals in large quantities can cause oxidative damage in muscle tissue, liver, blood and other tissues. Sports people with strenuous activities require additional exogenous antioxidants. But the trained muscles more resistant to oxygen stress unless the sport so hard and long that requires the use of high levels of muscle glycogen (Santosa Giriwijoyo and Dikdik Zafar Sidik, 2012: 136).

CONCLUSION

The conclusion of this research is the provision of theobromine and caffeine in the treatment group and the comparison does not influence significantly to the levels of lactic acid to examine the degree of muscle fatigue.

ACKNOWLEDGMENTS

On this occasion the researcher was grateful to all employees in the Department of Sport Science, Faculty of Sport Science, Universitas Negeri Semarang (UNNES) who have provided guidance and time so that I was able to complete this study, the Department of Biology who has given permission to conduct research.

REFERENCES

- Almahdy A, Nurul Afifah Almunawwarah, dan Najmiatul Fitria. 2013. Uji Efek Teratogen Kakao Bubuk Pada Fetus Mencit Putih. Fakultas Farmasi Universitas Andalas. Vol 2 no. 1, Januari 2013.
- Bennet Alan Weinberg and K.Bealer. 2002. *The Miracle of Caffeine, Manfaat Tak Terduga Kafein Berdasarkan Penelitian Paling Mutakhir.*
- Bimo Wahyu Angga Saputro. 2016. "Perbandingan Pemberian Vitamin C dan Kafein Terhadap Tingkat Kelelahan Otot Saat Melakukan Aktivitas Fisik Maksimal Eksperimen Pada Tikus Stain Wistar (*Rattus norvegicus*)". *Skripsi.* Program Sarjana Universitas Negeri Semarang
- Chikita Rizqi Hanifati. 2015. Pengaruh Minuman Kopi Minim Kafein Terhadap Vo2max dan Pemulihan Denyut Nadi Setelah Melakukan Treadmill. *Skripsi.* Jember Program Sarjana Universitas Jember.
- Cholid Narbuko dan Abu Achmadi. 2008. *Metode Penelitian.* Jakarta. Bumi Aksara
- Diah Kusumawati. 2004., *Bersahabat Dengan Hewan Coba.* Yogyakarta
- Elly Herwana, Laurentia L. Pudjiadi, Rachman Wahab, dkk. 2005. Efek Pemberian Minuman Stimulan Terhadap Kelelahan Pada Tikus. Januari – Maret 2005. Vol. 24 No.1
- Erna Febriani. 2016. Pengaruh Aktivitas Fisik Maksimal, Suplementasi Vitamin C dan Vitamin E Terhadap Kadar Asam Laktat (Studi Eksperimen pada Tikus Wistar Jantan). *Skripsi.* Program Sarjana Universitas Negeri Semarang.
- Eva Martinez-Pinilla, Ainhoa Onatibia-Astibia, and Rafael Franco. 2015. *The Relevance of Theobromine for the Beneficial Effects of Cocoa Consumption.* 20 February 2015.
- Giri Wiarto. 2013. *Fisiologi dan Olahraga.* Yogyakarta: Graha Ilmu.
- Hayati.,2012. Penggunaan Kafein Dalam Dunia Olahraga dan Efeknya Sebagai Ergogenic. Wahana
- Hery Wijayanto, Tri Wahyu Pangestiniingsih, dan Erdiansyah Rahmi. 2007. Pengaruh Pemberian Kafein Pada Masa Organogenesis Terhadap

- Berat Lahir Fetus Tikus Putih (*Rattus norvegicus*). Universitas Gajah Mada Yogyakarta. Volum 1 No. 2 September 2007.
- I Made Yoga Parwata. 2015. Kelelahan dan Recovery Dalam Olahraga. Volum 1. Juni 2015. 2 – 13.
- INyoman Arsana. 2014. Ekstrak Kulit Buah Manggis (*Garcinia mangostana* L.) dan Pelatihan Fisik Menurunkan Stres Oksidatif Pada Tikus Wistar (*Rattus Norvegicus*) Selama Aktivitas Fisik Maksimal. *Disertasi*. Denpasar: Program Pascasarjana Universitas Udayana.
- Issna Putra Perdana. 2016. Efektifitas Pemberian Kafein dan Aktivitas Fisik Terhadap Penurunan Kolesterol Pada Tikus Putih. *Skripsi*. Program Sarjana Universitas Negeri Semarang.
- Lala Herawati. 2009. *Memori dan Pembelajaran Efektif*. Bandung: Buku Kita.
- Moh. Nazir. 2009. *Metode Penelitian*. Bogor: Ghalia Indonesia.
- Nanik Lidyawati Sugianto. 2011. Pemberian Jus Delima Merah (*Punica granatum*) Dapat Meningkatkan Kadar Glutation Peroksidase Darah Pada Mencit (*Mus musculus*) Dengan Aktivitas Fisik Maksimal. *Tesis*. Denpasar: Program Pascasarjana Universitas Udayana.
- Novita Sari Harahap. 2008. Pengaruh Aktifitas Fisik Maksimal Terhadap Jumlah Leukosit dan Hitung Jenis Leukosit Pada Mencit (*Mus Musculus L*) Jantan". *Tesis*. Program Pascasarjana Universitas Sumatra Utara Medan
- Pangkalan Ide. 2008. *Dark Chocolate Healing, Mengungkap Khasiat Cokelat terhadap Siklus Darah dan Imunitas Tubuh*. PT Elex Media Komputindo.
- Rusli Lutan, dkk. 2000. *Kesehatan Olahraga*. Departemen Pendidikan Dan Kebudayaan.
- Santosa Giriwijoyo, Didik Zafar Sidik. 2012. *Ilmu Faal Olahraga*. Bandung. PT Remaja Rosdakarya.
- Santosa Giriwijoyo, Didik Zafar Sidik. 2013. *Ilmu Kesehatan Olahraga*.
- Suharsimi Arikunto. 2009. *Manajemen Penelitian*. Jakarta: Rineka Cipta
- Sugiyono. 2010. *Metode Penelitian Pendekatan Kuantitatif, Kualitatif, dan R dan D*. Jakarta. Rineka Cipta

Toho Cholik Mutohir.2011. *Berkarakter dengan Berolahraga, Berolahraga dengan Berkarakter*. Jakarta: Sport Media.

CASE-FINDING MODEL OF MALNOURISHED CHILDREN (UNDER AND OVER-NUTRITION) IN INDONESIA

Lukman Fauzi^{1*}, Oktia Woro Kasmini Handayani¹, Setya Rahayu²

¹ Public Health Science Department, Universitas Negeri Semarang, F5 Building 2nd Floor,
Sekaran Campus, Gunungpati, Semarang City

² Spors Science Department, Universitas Negeri Semarang, F1 Building 1st Floor, Sekaran
Campus, Gunungpati, Semarang City

*Corresponding email: lukman.ikm@mail.unnes.ac.id

ABSTRACT

The prevalence of obese nationally in Indonesia was 11.9%. UNICEF stated that 28 million stunted children are in East Asia-Pacific. Evidence showed that about 80% of children with malnutrition who have been identified through active case finding. The aim of this research was to investigate the implementation of case-finding model (process, strength, weakness, opportunity, threat, and effectiveness) of malnourished children, i.e. under-nutrition and over-nutrition, in Indonesia.

The research approach was qualitative approach; the focus was on case-finding model of malnourished children (under and over-nutrition). The data used mostly were secondary data (from previous studies and applicable policies), collected from document study, while supporting data were primary data, collected from in-depth interview or focus group discussion (FGD) with health/ community volunteers or medical/ health services officer.

The results found that all case-finding models of malnoursihed children in Indonesia involved community empowerment in collaboration with health volunteers, family welfare program (PKK) members and partner institutions such as universities and schools. The success rate of the model was influenced by: 1) Policies and support from health institutions as a leader in the health program in the community, 2) The existing potential in the community, 3) The leadership style of the head of the community

organization involved, 4) Commitment from partner institutions supported by the policy of the upper level strata.

Keywords: under-nutrition, over-nutrition, case-finding model

INTRODUCTION

WHO stated an estimated 41 million children under the age of 5 years were overweight or obese in 2014. Once considered a high-income country problem, overweight and obesity are now on the rise in low- and middle-income countries, particularly in urban settings. Nearly half of the children under 5 who were overweight or obese in 2014 lived in Asia. Overweight and obesity are linked to more deaths worldwide than underweight. Globally there are more people who are obese than underweight. This occurs in every region except parts of sub-Saharan Africa and Asia (WHO 2016b). The highest prevalence of overweight in infants and children occurred in the upper-middle income countries, but the fastest growth is precisely in lower-middle income countries, such as Indonesia (McMurray et al, 2000; Wang, 2001).

Children who are overweight or obese are at a higher risk of developing serious health problems, including type 2 diabetes, high blood pressure, asthma and other respiratory problems, sleep disorders, and liver disease. They may also suffer from psychological effects, such as low self-esteem, depression and social isolation. Childhood overweight and obesity also increase the risk of obesity, non-communicable diseases (NCDs), premature death and disability in adulthood. Finally, the economic costs of the escalating problem of childhood overweight and obesity are considerable, both in terms of the enormous financial strains it places on health-care systems and in terms of lost economic productivity (WHO 2014).

In Indonesia, one of the public health problems that are being faced is the double burden of nutritional problems, i.e. under and over-nutrition. National Health Research (2013) showed that nationally estimated prevalence of children under-five with under-nutrition increased from 18.4 % (2007) to 19.6% (2013). The prevalence of obese nationally in Indonesia was 11.9 %. There are 12 provinces that have problems

obese children higher than the national average. One of them is Central Java Province, with the capital city of Semarang (Badan Penelitian dan Pengembangan Kesehatan 2013).

Evidence shows that about 80 per cent of children with malnutrition who have been identified through active case finding. **It is** involved community volunteers regularly screen and monitor all young children so that cases of malnutrition can be identified early and treated immediately. This leads to high coverage, faster rehabilitation, and lower mortality (Prudhon et al. 2006). Case-finding process of under and over-nourished children can be done by active and passive case-finding. Passive case-finding is defined as detecting active under and over-nutrition among symptomatic children who present to medical/health services for diagnosis of symptoms. Active case-finding requires a special effort by the health care system to increase the detection of malnutrition in a given population.

To solve health problems, practitioners use a four-step scientific approach that includes data collection, assessment, hypothesis testing, and action. Public health problems/data are collected among the population through surveillance. Case-finding is one of the important surveillance processes that influences the decision making. Research Problems: How are the similarities of case-finding model (process, strength, Thailand weakness, opportunity, threat, and effectiveness) of malnourished children, i.e. under-nutrition and over-nutrition, in Indonesia and Thailand.

METHODS

The research approach was qualitative approach; the focus was on case-finding model of malnourished children (under and over-nutrition). The data used mostly were secondary data (from previous studies and applicable policies), collected from document study, while supporting data are primary data, collected from in-depth interview or focus group discussion (FGD) with health/ community volunteers or medical/ health services officer. Interview will be focused to get supporting situation related to case-finding model of under and over-nutrition (process, strength, weakness, opportunity, threat, and effectiveness).

Determination of initial informants were acquired by purposive technique. Informants consist of 3 children under 5 years mothers, 1 person from community health centre, 2 community health centre heads, 2 integrated health service post health volunteers, 1 person of nutrient section on Semarang City Health Office, so that initial informants are 9 persons. The instruments used were observation guide, interview guide, and FGD guide. The data collected in form of primary data and secondary data.

The research in Indonesia was conducted on Semarang to obtain primary datas. This region was selected based on: 1) It was part of research road map (the research was started in 2008 and on) that will deliver a policy and program related with community nutritional status improvement 2) Semarang which was located in Jawa Tengah Province, has plenty nutritional cases (nutritional insufficient, malnutrition, obesity) causing Jawa Tengah, in 2013, is on rank 13 of 33 provinces in Indonesia for malnutrition and insufficient nutrition, with percentage of 17.6% or 480,441 children (Directorate General of Nutrition and Mother and Child Health, 2013). 3) Consideration of accessibility and ease of data retrieval, also field observation.

Data analysis technique used in this research was Miles and Huberman model (Basrowi, 2008), which covers three concurrent activities consist of data reduction, data display and conclusion (verification). Data collection and data analysis were interactive cyclic process, where researcher should always be ready to move in four-axis coil while data is collected by alternating motion between the activity of data reduction, presentation, and conclusion or verification.

RESULTS AND DISCUSSION

Nutrition case found that become main concern is malnutrition case, though in the community there are children under five with under weight and over weight as well. The malnutrition case is found from integrated health service post (Posyandu) health volunteer report to public health center (puskesmas). It is determined by the result of children under five weight scaling on posyandu event or observation result from home visit by health volunteer. There are also findings based on the report to posyandu health

volunteer from family welfare program (PKK) members. The findings will all be reported both formally or informally to puskesmas through nutrition section, to obtain proper care.

The report is presented in health volunteer's monthly coordination meeting on the puskesmas and in the nutrition section coordination on related events (such as health training, healthy children under five years competition and family plan activity). Cases found by health volunteers are recorded in posyandu log book along with children under five monthly body weight note and treatment applied.

For malnutrition cases, the cure treatment seriously proceed through Nutrition House program, until the nutrition status is improved. Furthermore, no other partner particularly involved in finding nor solving malnutrition case in the community. There has been some models tested in small scale on urban and sub urban region of Semarang in order to find nutritional case as early as possible, so that the recovery could be faster and minimize adverse effect. The models are :

1) Magnification system of early detection in the community

This model is applied on urban region with active posyandu with the chief and the members involve in monthly activities. The activities can be in form of (1) Case finding by refer to health card or weight scaling record on the posyandu if body weight does not increase in consecutive three months. (2) Case finding in the neighbourhood or residential region. (3) Data collection. (4) Reporting.

The nutrition section person in charge in puskesmas acts as activity responsible person and field implementer by posyandu health volunteers and family welfare program members.

2) Partnership improvement through school institution

The objective is to educate healthy behaviour to achieve well nutrition status. Furthermore, to identify nutritional cases among the students. The activities consist of (1) Training for teacher (2) Health education for students (3) Guidance of healthy behaviour (4) Periodically school health

service and finding of nutritional case (5) Providing health school environment.

The school responsible for the program and appointed teacher or staff as implementer.

3) Optimizing the function of posyandu

Posyandu model is consider as developable potention. In this research, the health volunteer chief is very active, meanwhile members participate partially. The activities consist of (1) Cadre regeneration (2) Refresh training for health volunteers (3) information sharing with up to date method for mother of children under five years (4) Conducting a children under five years class for a post with large nutritional cases (which contain finding, conselling and reporting) (5) Conducting partnership with Universities having Health Faculty.

The puskesmas nutrition person in charge as responsible person, posyandu health volunteers as field implementors and university students and lectures as field adviser.

4) Improvement of community empowerment through childrent nutritional care post

This model is implemented on sub urban region having posyandu that potentially active. All potential resources are utilized as much as possible. The activities consist of (1) Case finding by refer to health card or weight scaling record on the posyandu if body weight does not increase in consecutive three months and case finding in the neighbourhood or residential region. (2) Reporting to puskesmas for treatment (3) Condition update during treatment process. (4) Family counseling (5) Data collection.

The nutrition section person in charge in puskesmas acts as activity responsible person and field implementer by posyandu health volunteers, family welfare program members and students of partnership university.

All case-finding models of malnourished children in the community is a form of community empowerment which is also the utilization of the existing potential in the community. Some problems that arise in relation to the model being run are:

- 1) The leadership style of the health volunteer leader who does most of the work on his own, does not involve a lot of members. Leadership which is the process of influencing or setting an example to the members in an effort to achieve common goals, can not be done well. As health volunteer leader ideally has: (1) the function of instruction (assigning) to the members in accordance with their responsible, (2) the function of consultation (two-way communication), (3) the function of participation (the leader tries to control the situation and can engage in activities), (4) the function of delegation (divide tasks to members) and (5) the function of control. The leadership style of the health volunteer leader, can be classified as tend towards the dominant paternalistic on authoritarianism, which is 1) all more decisions are taken by the leader, who considers himself most capable and master all kinds of problems in the field, 2) treats his members as incapable person in the task, and want to help or be good, so as not to charge the task to the members. The role of the leader is an important part of the model's success, as has been found in Karen (2013), that the role of leader in the form of leadership support will affect the success of the health program. Leadership as a system of relationships between leaders and members is important, and appropriate leadership will have a positive impact on the duty (Habiba, 2013, Osabiya, 2015).
- 2) Community empowerment by health volunteer members and PKK which is potential to be utilized can not run well in accordance with the given task. The potential that belongs is consistent with De Silva (2007); Handayani (2013), which stated that the high maternal social capital and cultural system that is owned by mothers in social life can have a positive impact on the nutritional status of children. Other community empowerment, like in Cameroon, where efforts to improve the nutritional status of children were done through strengthening local health volunteer that emphasize the health mission within

social groups in the community (Plan, 2009). The empowerment of health volunteer in this model is more directed to the implementation activities in the field, although still it was involved in program planning and evaluation activities, but the emphasis is more on providing information. This empowerment can foster self-reliance of the community on the pattern of healthy nutrition parenting that has an important role to be able to overcome unsupporting social and environmental factors. This is in line with the results of Eileen (2007), that nutrition improvement programs should also be designed and targeting to increase self-reliance in the community.

- 3) Models that are applied based on local potential can run with efficiency, do not require long periods of time, low obstacles or constraints, the possibility of disbursed funds can also be limited, and quick results. This is reflected in the results achieved by the model of early detection strengthening systems in the community, which include posyandu and active health volunteer compared to the posyandu function optimization model with toddler classes, which included posyandu and less active health volunteer, then reorganized and trained to activate them, although both models are conducted in the same area of puskesmas. These results are in line with research that community empowerment is a top priority, where programs are directed to encourage community engagement with the implementation of evidence based interventions, and engage them in planning, implementation and evaluation. Potentials used for empowerment can come from parents, communities and institutions (Junghyun Lim, 2017, Robert EB, 2017).
- 4) The model of enhancing partnerships through school institutions will result in knowledge and behavior improvement of healthy and clean life and behavior among children that can support health status and nutritional status improvement. Health education provided should be done as early as possible to provide basic knowledge of health and nutrition as well as forming healthy behavior among children. The results of model implementation will have good sustainability if the principals play a role and support through their policies (Vikram Niranjan, 2017; Pimo Alice, 2016).

CONCLUSION

The results found that all case-finding models of malnourished children in Indonesia involved community empowerment in collaboration with health volunteers, family welfare program (PKK) members and partner institutions such as universities and schools. The success rate of the model was influenced by: 1) Policies and support from health institutions as a leader in the health program in the community, 2) The existing potential in the community, 3) The leadership style of the head of the community organization involved, 4) Commitment from partner institutions supported by the policy of the upper level strata.

REFERENCES

- Ainy Asmaripa. 2010. Desa Siaga dan Manajemen Kesehatan Bencana. *Jurnal Ilmu Kesehatan Masyarakat*, 1(01).
- Badan Penelitian dan Pengembangan Kesehatan, 2013. Riset Kesehatan Dasar (RISKESDAS) 2013. *Laporan Nasional 2013*, pp.1–384.
- Blössner, M. & de Onis, M., 2005. *Malnutrition: quantifying the health impact at national and local levels*, Geneva: World Health Organization (WHO Environmental Burden of Disease Series, No. 12)
- Felland Laurie E., Lauer Johanna, Cunningham Peter J. 2009. Suburban Poverty and the Health Care Safety Net. *HSC Research Brief 13*
- Gordon, B., Mackay, R. & Rehfuess, E., 2004. *Inheriting the World: The Atlas of Children's Health and the Environment*, Geneva: World Health Organization.
- Ivanovic, D., Rodriguez, Perez, H. 2008. Twelve-year Follow-up Study of The Impact of Nutritional Status at The Onset of Elementary School on Later Educational Situation of Chilean School-age Children, *European Journal of Clinical Nutrition* 62, 18-31p.
- Lopez Russell P, Hynes H Patricia. 2006. Obesity, Physical Activity, and The Urban Environment: Public Health Research Needs. *Environmental Health: A Global Access Science Source* 2006, 5:25
- McMurray RG et al. 2000. The Influence of Physical Activity, Socioeconomic Status, and Ethnicity on The Weight Status of Adolescents. *Obesity Research*, 8:130–139.

Prudhon, C. et al., 2006. Proceedings of the WHO, UNICEF, and SCN informal consultation on community-based management of severe malnutrition in children. *Food and Nutrition Bulletin*, 27(SUPPL.3).

Tieleman, L., 2014. Health and Nutrition in Australia. , (June), pp.1–7.

Wang Y. 2001. Cross-national Comparison of Childhood Obesity: The Epidemic and The Relationship between Obesity and Socioeconomic Status. *International Journal of Epidemiology*, 30:1129–1136.

WHO, 2016a. GHO | Visualizations | Joint child malnutrition estimates 2016 (UNICEF-WHO-WB). WHO. Available at: <http://apps.who.int/gho/data/node.wrapper.nutrition-2016?lang=en&showonly=nutrition> [Accessed February 28, 2017].

WHO, 2014. *Global Nutrition Targets 2025: Childhood Overweight Policy Brief (WHO/NMH/NHD/14.6)*, Geneva: World Health Organization.

WHO, 2016b. WHO | Obesity and overweight. WHO. Available at: <http://www.who.int/mediacentre/factsheets/fs311/en/> [Accessed February 28, 2017].

**THE DEVELOPMENT OF PERSONAL COMPUTER BASED
ACCELEROMETER
TO FIND OUT THE CHARACTERISTICS OF SPRINT
BY USING WIRELESS TECHNOLOGY**

Andry Akhiruyanto, S.Pd, M.Pd¹

¹ Universitas Negeri Semarang

Abstract

Speed measurement tool that mostly used in running activities is still a stopwatch which can measure the time required to travel a certain distance. The stopwatch can only measure the average speed and not the acceleration and instantaneous speed during running. Though acceleration, instantaneous speed, length and frequency of steps are important components in sprint. Therefore, an accurate, inexpensive and reliable measuring instrument is required to measure all the components of sprint. This research's aims are a) as an activity monitoring tool of sprints use an accurate and reliable android based accelerometer with low cost; b) finding out the instantaneous speed, length, and step's frequency of sprint c) producing an Android-based accelerometer product that can find out the characteristics of the sprint. The research method used was research and development method which includes development model, development procedure, and product trial. The model stage and development procedure are the steps of making the product starting from preparing with tilt v3.0 three axes accelerometer with the arrangement until making a program by using Microsoft Visual Basic (VB). The product trial is done by validation of telemetry expert and VB programmer. The research subjects are beginner athletes. The observation sheet is prepared to retrieve Raw ADC data as the accelerometer and questioner as the product user response. The result of the study shows that accelerometers can transmit data and processed by the program that had been made. The program then displays the information of running characteristics i.e. the speed, length, and the number steps. There is an increase in speed ranging from 0 to 30 meters, then there is a decrease in speed and increase again at almost 40 meters. In the further than 40 meters, data loss occurs due to Bluetooth coverage troubled by buildings around the trial area. It can be concluded that the accelerometer and the program created, in real time, has provided information on sprint characteristics but it needs revamping to reduce signal trouble so that data of running can be obtained completely up to 100 meters.

Keywords: accelerometer, personal computer, real-time, running characteristics

INTRODUCTION

According to Ballesteros (1993), the speed component is one of the most important factors for sprint. Sprint, based on running step, contains of some steps: a) reaction and boost, b) acceleration, c) transition/change, and d) speed maintenance. Running speed is determined by length and frequency of step (steps per one time unit). Therefore, a runner must be able to improve one or both of them. The importance of sprint characteristics such as acceleration, speed, length and step frequency require a measuring tool that can accurately display necessary information.

The observation of running activities such as speed is generally done by using a stopwatch with various accuracy. The use of the stopwatch can only measure the average speed and not the acceleration nor the instantaneous speed. Acceleration and instantaneous speed at runtime is very important to know the characteristics of runners. Therefore, an accurate, reliable and low cost tool which is able to monitor the running activities is needed.

A sensor can be used to monitor physical phenomena such as speed, acceleration, force, pressure or flow into the electrical quantities, one of them is accelerometer sensor. Accelerometer is a sensor that detects changes in velocity (acceleration or deceleration) in one direction or more in the form of electrical signals.

Accelerometer sensor is suitable for people with running activities because it is not disturbing. The acceleration produced by accelerometer used by the runner can be processed into speed and distance by using basic physics calculation formula of motion. However, the electrical signal generated by the accelerometer will form a fluctuating signal, especially if it is attempted to be applied to running motion. Therefore, signal processing and filtering are required to smoothen the resulted signal. This tool is a microcontroller which also changes the analog signal from the accelerometer to digital (Analog to Digital Converter) to be processed on the personal computer.

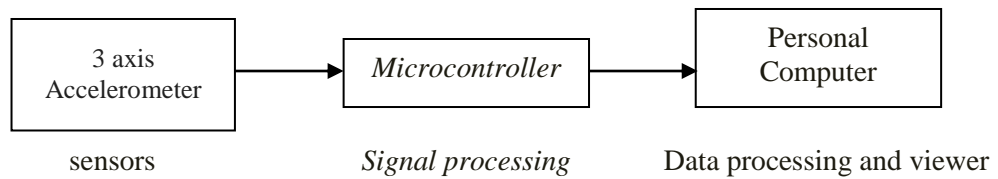

Figure 1. Block of accelerometer diagram and advanced process

Data communication from microcontroller with the personal computer may use various ways such as wireless technology via radio waves or Bluetooth technology. Bluetooth is a standard wireless technology used to exchange information between devices.

Based on the introduction above, this research aims to: a) design a monitoring tool of sprint activity by using a personal computer-based accelerometer with an accurate and reliable wireless technology; b) know the instantaneous speed, length, and frequency of sprint steps in real time; c) produce personal computer(PC)-based accelerometer products which is able to find out the characteristics of sprint.

METHODS

The research used development research method which includes development model, development procedure, and product trial.

Figure step and development procedure are the steps of making the product starting from preparing witilt v3.0 three axes accelerometer with the arrangement until making the program by using Microsoft Visual Basic (VB). The test of the product is done by validation of telemetry expert and VB programmer. Research subjects were beginner athletes. The observation sheet was prepared to retrieve Raw ADC data as the accelerometer and questionnaire output as the product user response.

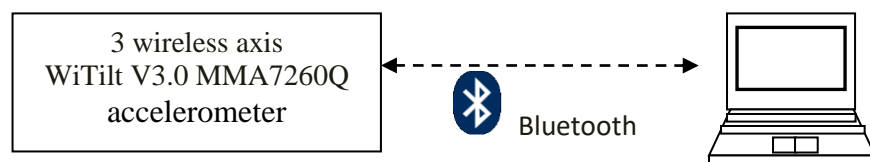

Figure 2. Design chart of the running activity monitoring system

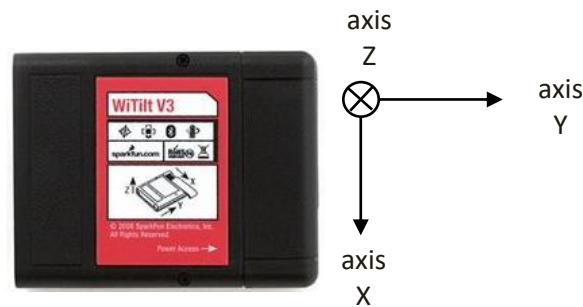

Figure 3. WiTilt V 3.0 MMA7260Q 3 axis

From figure 3 above, container design is made to be placed on the body of the person to be tested. To avoid accelerometer position change before it is operated, the accelerometer is planned to be placed on the part of the body that is relatively less movement at the waist. Thus the accelerometer will be made in the shape of a belt with an accelerometer in the back waist position.

1) Expert Validation

Expert validation is required to ensure that the data obtained and processed in a pre-made system is completely valid and reliable. Experts to be involved are athletic trainers and lecturers.

2) Field Trial

The trial phase is firstly conducted into a small group of limited subjects to ensure system reliability and then newly tested on a broader scale involving

more subjects. At the end of small group trials, if any deviation is found there will be a repair effort as necessary to address them.

3) Revision and improvement of expert input and test results

This stage is very important to avoid mistakes when the system has been made, ready to be the final product.

Instruments used in product development are observation guidelines, questionnaires, and assessment guidelines. Observation is used to find out the efficiency and effectiveness of product operational systems, the questionnaires are used to find out the subject's feedback and expert opinion. Assessment guidelines are used to obtain information in the form of a nominative assessment of the product to be produced.

The trial data will be analyzed descriptively analytically, by performing a thorough examination of the information and/or feedback that can be obtained from the trial subjects. The product prototype can be said to function properly when it can be operated in accordance with the design, easy, fast and can provide accurate and accountable information.

RESULTS AND DISCUSSION

The design of the system aims to measure the speed, length and number of steps run by using the accelerometer Witilt v 3.0 which has 3 axis measurements (X, Y, Z) and send the data by using Bluetooth to be processed and displayed on the personal computer by using Microsoft Visual Basic program.

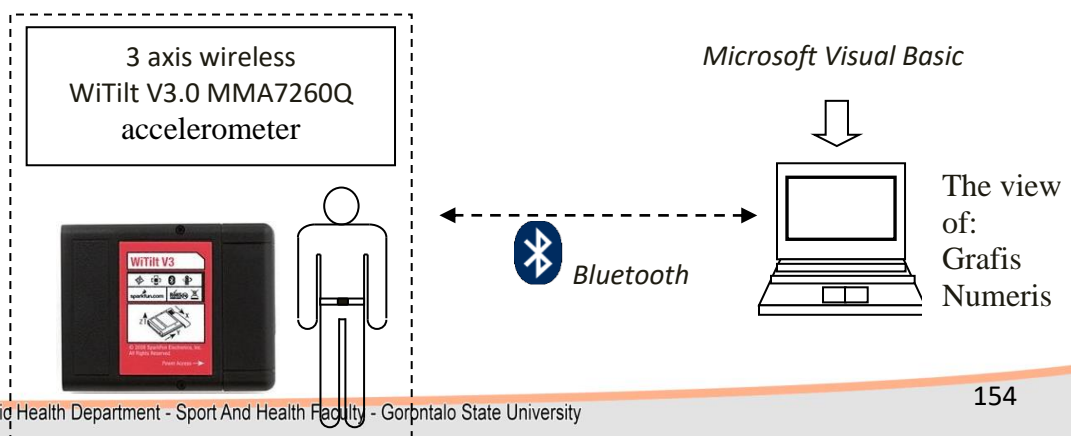

Figure 5. DiagramSystem

In accordance with the system diagram above, the steps of designing and manufacturing of products are as follows:

- 1) Prepare the Witilt V3.0 MMA7260Q - 3 wireless axis accelerometer (Sparkfun, USA) and learn its characteristics
- 2) Prepare the accelerometer container in the form of a belt.
- 3) Prepare a personal computer equipped with Bluetooth and set the communication path (COM) to be used
- 4) Build a processing program and data viewer sent from accelerometer by using Microsoft Visual Basic.

Research Procedure

The research development of personal computer-based accelerometer to find out the characteristics of running uses the procedure as follows:

- 1) Recognizing the characteristics of the witilt v3.0 accelerometer. The 3-axis MMA7260Q accelerometer sensor can measure dynamic acceleration in 3 directions, i.e. X, Y and Z axes. The sensors features: a) Active channels to select from which axes will be partially or completely activated; b) Calibration features for calibrating accelerometers of each data retrieval; c) Sensor range for selecting device sensitivity in measurement (1.5g, 2g, 4g and 6g); d) Display mode to select the output data (Raw ADC, gravity, binary or degree); e) Threshold set to select output data only based on certain predefined value; f) Output frequency to determine the desired maximum frequency (50Hz for degrees, 135Hz for gravity, 220Hz for Raw ADC and 610 Hz for binary). In addition to the above features, witilt v3.0 also features a built-in rechargeable battery, activation status (LED) and a 1st class Bluetooth connection that can reach 100m (line of sight) or 30m indoor.

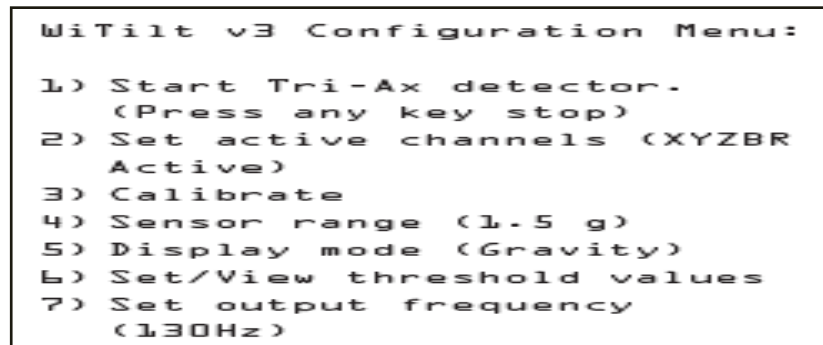

Figure 6. Configuration menu on Witilt v3.0

- 2) The belt as the accelerometer sensor container should be flexible in accordance with the waist circumference of the runner but fastened to ensure that no data transmission other than the data caused by running motion.



Figure 7. Accelerometer belt

- 3) Preparing the personal computer with Bluetooth connection. Witilt v3.0 has a key password to connect to Bluetooth on the computer. A standard passkey is a 4-digit number that is 1234. This character must be entered so that wilt v3.0 is recognized by the computer and uses the HyperTerminal application available on the Microsoft Windows operating system (Start> All Programs> Accessories> Communications> Hyperterminal).

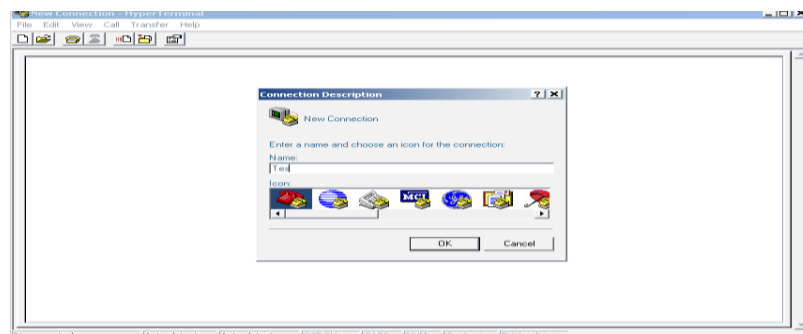

Figure 8. Hyperterminal application

- 4) Design and create programs to monitor sprint characteristics. The program is created by using Visual Basic 6 and contains information about the identity of runners, running time (day, date, hour), running characteristics consisting of acceleration, speed, step length and a number of steps to run in 100m.

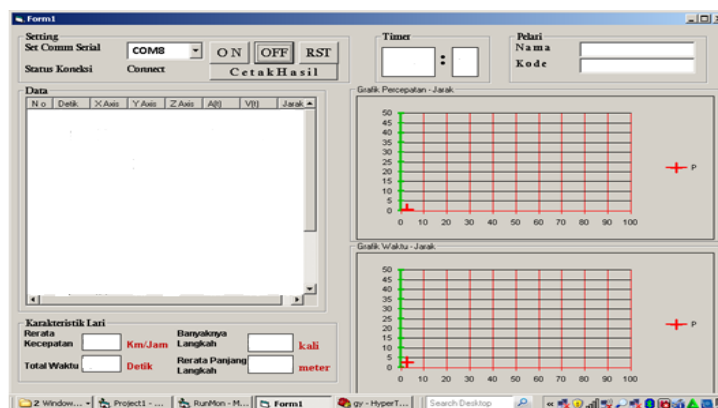

Figure 9. Program display

- 5) After wtilt v3.0 accelerometer is connected with Bluetooth computer and hyper terminal application, a menu configuration will appear as shown in Figure 4.2. Furthermore, to obtain reliable results need to do: a) set the sensor range (selected 1.5g); b) sensor calibration by determining the highest and lowest output of each axis obtained by X-axis midpoint 468, width 250; Y-axis midpoint 461, width 251; Z axis midpoint 515, width 252; c) set display mode (selected Raw ADC); d) set output frequency (220Hz selected); set the active channel (taken output from all three axes at once X, Y, Z); e) Ready data retrieval.
- 6) Before taking the data, it is necessary to prepare the research instrument including observation sheet to retrieve Raw ADC data from the three axes and questionnaire sheet to know the response of research subject and sheet. Then the data will be processed by the Visual Basic program that has been created.

7) Data has been obtained in the form of Raw ADC from accelerometer will be processed by the program using equation 3 and 4 to get information about speed and distance. The next program to process the data with the peak detection method is to process the filter to take data acceleration above the value of 1g which is considered as a curve or a single step run. The test results show that up to 40 meters distance is done 15 steps with an average step length of 2.3 meters.

CONCLUSIONS

Based on the results and previous discussion it can be concluded that:

- 1) The design of sprint activity monitoring tool by using the personal computer-based accelerometer with wireless technology can accurately and reliably measure up to 40 meters distance.
- 2) In real time, during runs, the program can display the instantaneous speed information, length and number of steps.
- 3) It has been produced accelerometer products based on personal computer (PC) that can know the characteristics of sprint up to 40 meters.

REFERENCES

- Astrand, P.O. 1986. *Textbook of Work Physiologi – Physiological Basis of Exercise*. New York: Mc Graw-Hill Book Compani.
- Ballesteros, Jose Manuel. 1984. *Field and Track Athletics. Basic Coaching Manual*. England: AAF.
- Foster, R.C. 2005. Precision and Accuracy of an Ankle-Worn Akselerometer-based Pedometer in Step Counting and Energy Expenditure. *Jurnal Preventive Medicine*, Volume 41, hal 778-783.
- Gotama, Andreas. 2008. Pemantauan Aktifitas Fisik Langkah Kaki Menggunakan Akselerometer Berbasis Teknologi Bluetooth. *Artikel Skripsi*. Depok: Universitas Indonesia.
- Graham, Brian Barkley. 2000. *Using an Akselerometer Sensor to Measure Human Hand Motion*. Tesis. Massachusetts Institute of Technology.

- Harsono. 1988. *Coaching dan Aspek-Aspek Psikologis dalam Coaching*. Jakarta: P2LPTK, Depdikbud.
- Moritz, E.F dan Steve Haake (Editor).2009. *The Engineering of Sport 6*. Vol. 3. Developments of Innovation. New York: Springer.
- Widada, Wahyu dan Sri Kliwati. 2007. Measurement Of Vehicle Acceleration Performance Using Three-Axial Accelerometer. *Prosiding Seminar Nasional Teknologi (SNT)*



ISPHE

INTERNATIONAL SEMINAR
PUBLIC HEALTH EDUCATION



ISBN 978-602-6204-25-7



9

786026

204257